

Industrial Barcode Printer

MB241 Series

Thermal Transfer • Direct Thermal

Series Models

MB241/MB341

MB241T/MB341T



Service Manual

Copyright Information

©2024 TSC Auto ID Technology Co., Ltd.

The copyright in this manual, the software and firmware in the printer described are owned by TSC Auto ID Technology Co., Ltd. All rights reserved.

CG Triumvirate is a trademark of Agfa Corporation. CG Triumvirate Bold Condensed font is under license from the Monotype Corporation. Windows is a registered trademark of Microsoft Corporation.

All other trademarks are the property of their respective owners. Information in this document is subject to change without notice and does not represent a commitment on the part of TSC Auto ID Technology Co. No part of this manual may be reproduced or transmitted in any form or by any means, for any purpose other than the purchaser's personal use, without the expressed written permission of TSC Auto ID Technology Co.



Table of Contents

1. Fundamental of the System	1
1.1 Printer Overview	1
2. Electronics	4
2.1 Summary of the Board Connectors	4
2.2 Interface Pin Configuration	15
3. Replacing Parts	17
3.1 Before You Begin	17
3.2 Removing the Lower Front Panel	18
3.3 Removing the Electronics Cover	19
3.4 Replacing the Platen Roller Assembly	20
3.5 Replacing the Printhead Assembly	21
3.6 Replacing the Control Panel Assembly	23
3.7 Replacing the Main Board	24
3.8 Replacing the Label Supply Spindle	25
3.9 Replacing the Power Supply Unit	26
3.10 Replacing the Stepping Motor Assembly	27
3.11 Replacing the Gap/Black Mark Sensor Module	28
3.12 Cutter Module Installation (Option)	30
3.13 Peel-off Kit Installation (Option)	32

3.14 Replacing the Internal Full Rewinder Kit (Option).....	36
3.15 Slot-in Wireless Housing Installation (Option)	40
3.16 GPIO Interface Assembly Installation (Option)	41
3.17 Bluetooth Module Installation (Option)	44
3.18 Linerless Kit Installation (Option)	46
4. Troubleshooting	53
4.1 Common Issues.....	53
4.2 Knob Adjustment	57
5. Maintenance	62
Revision History	65

1. Fundamental of the System

1.1 Printer Overview

Front View

■ MB241 Series



■ MB241T Series



- 1. LED indicator
- 2. 2.3" color LCD display
- 3. Front panel buttons
- 4. 3.5" color touch LCD
- 5. Media window
- 6. Paper exit chute
- 7. Media cover handle

Interior View

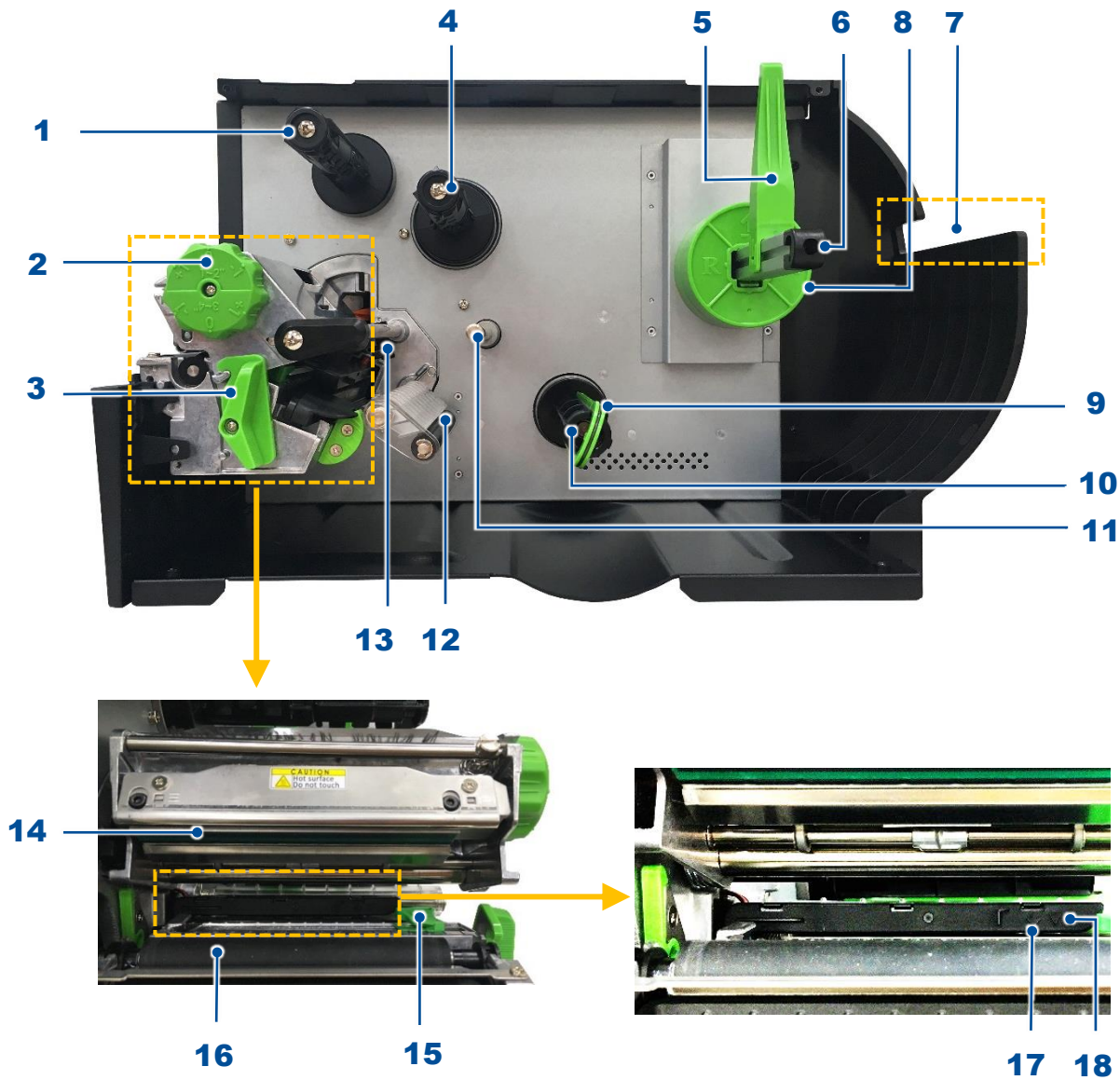

1. Ribbon rewind spindle
2. Print head pressure adjustment knob
3. Print head release lever
4. Ribbon supply spindle
5. Label roll guard
6. Label supply spindle
7. External label entrance chute
8. 3" core adapter
9. Liner securing clip (Optional kit of Peel-off module ass'y)
10. Liner rewind spindle (Optional kit of Peel-off module ass'y)
11. Media guide bar (Optional kit of Peel-off module ass'y)
12. Damper
13. Ribbon end sensor
14. Print head
15. Front label guide
16. Platen roller
17. Black mark sensor (shown as ↓)
18. Gap sensor (shown as ▽)

Rear View

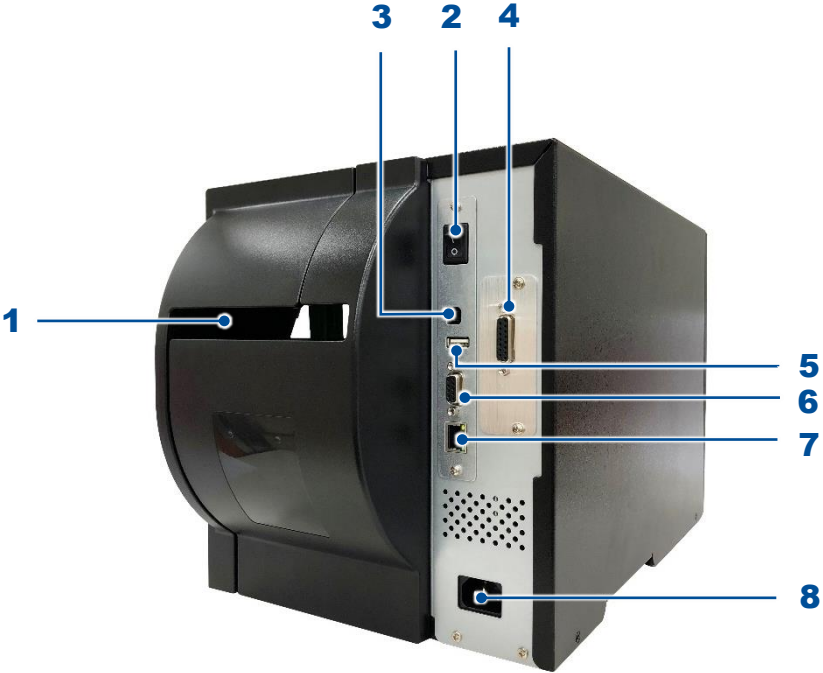

- 1. External label entrance chute
- 2. Power switch
- 3. USB interface (High speed mode)
- 4. Slot-in Wi-Fi or GPIO interface (Option)
- 5. USB host
- 6. RS-232C interface
- 7. Ethernet interface
- 8. Power cord socket

Note:
The interface picture here is for reference only. Please refer to the product specification for the interface availability.

2. Electronics

2.1 Summary of the Board Connectors

- Main board for MB241/ MB241T Series

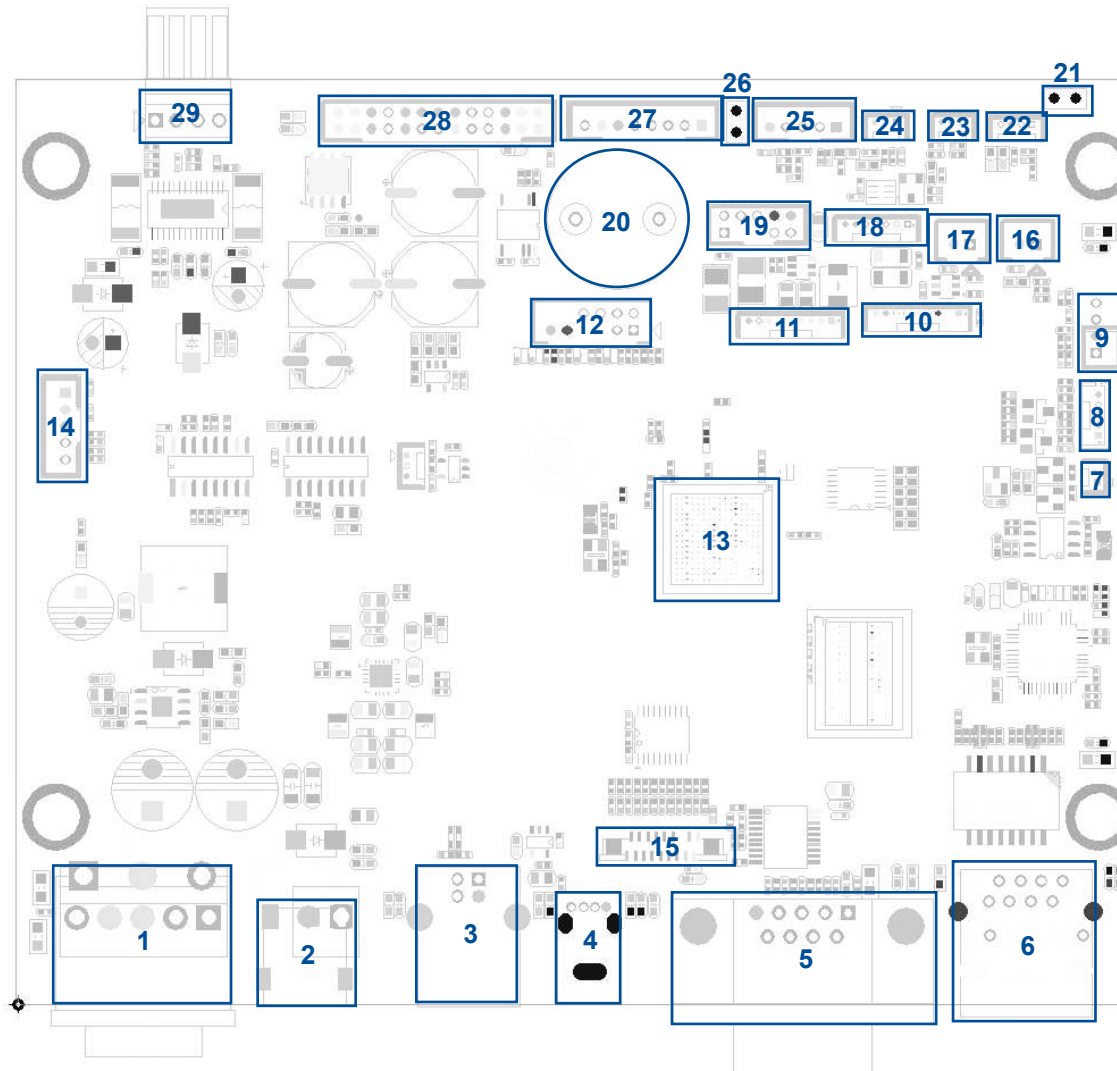

1. Power switch connector
2. Power supply (24V DC) connector
3. USB client connector
4. USB host connector
5. RS-232C connector
6. Ethernet connector
7. RTC battery connector
8. LED & key/ touch-function connector
9. Head open sensor connector
10. LCD panel (Interface 1, SPI LCD) connector
11. SD card connector
12. Wi-Fi connector
13. Micro processor
14. Liner rewinder connector
15. LCD panel (Interface 2, parallel LCD) connector
16. Gap receiver sensor connector
17. Gap emitter sensor connector
18. RFID connector
19. Wi-Fi/ Bluetooth connector
20. Buzzer
21. ESD cable connector
22. Ribbon end sensor connector
23. Ribbon encoder sensor connector
24. Black mark sensor connector
25. Peel-off sensor/ GPIO connector
26. ESD cable connector
27. Cutter/ GPIO connector
28. Printhead connector
29. Stepping motor connector

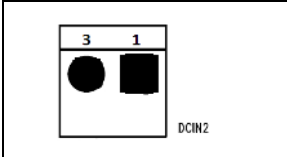
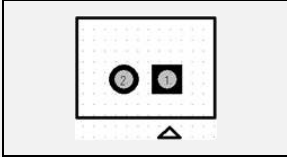
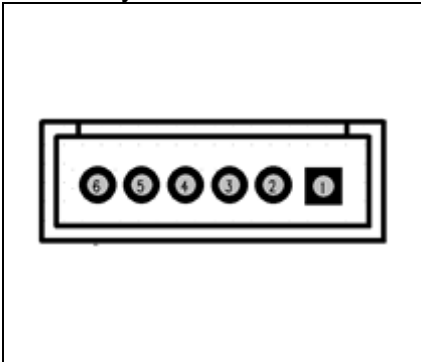
Connector	Description	Remark														
1	Power switch connector	SW1														
2	Power supply (24V DC) connector  <table border="1" data-bbox="739 272 1247 429"> <thead> <tr> <th>Pin</th> <th>Description</th> </tr> </thead> <tbody> <tr> <td>1</td> <td>+24V</td> </tr> <tr> <td>3</td> <td>GND</td> </tr> </tbody> </table>	Pin	Description	1	+24V	3	GND	DCIN2								
Pin	Description															
1	+24V															
3	GND															
3	USB client connector	USB1														
4	USB host connector	USB2														
5	RS-232C connector	RS1														
6	Ethernet connector	LAN1														
7	RTC battery connector  <table border="1" data-bbox="739 743 1247 900"> <thead> <tr> <th>Pin</th> <th>Description</th> </tr> </thead> <tbody> <tr> <td>1</td> <td>GND</td> </tr> <tr> <td>2</td> <td>Vbattery</td> </tr> </tbody> </table>	Pin	Description	1	GND	2	Vbattery	BT1								
Pin	Description															
1	GND															
2	Vbattery															
8	LED & key & touch-function connector  <table border="1" data-bbox="871 1031 1456 1394"> <thead> <tr> <th>Pin</th> <th>Description</th> </tr> </thead> <tbody> <tr> <td>1</td> <td>3.3V</td> </tr> <tr> <td>2</td> <td>KEY_SDA</td> </tr> <tr> <td>3</td> <td>KEY_SCL</td> </tr> <tr> <td>4</td> <td>KEY_INT</td> </tr> <tr> <td>5</td> <td>GND</td> </tr> <tr> <td>6</td> <td>TOUCH_INT</td> </tr> </tbody> </table>	Pin	Description	1	3.3V	2	KEY_SDA	3	KEY_SCL	4	KEY_INT	5	GND	6	TOUCH_INT	CON19
Pin	Description															
1	3.3V															
2	KEY_SDA															
3	KEY_SCL															
4	KEY_INT															
5	GND															
6	TOUCH_INT															

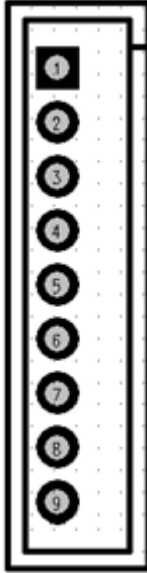

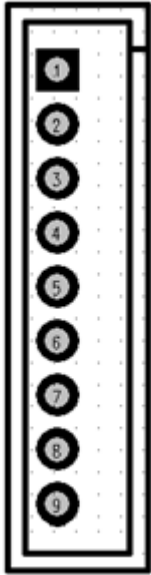
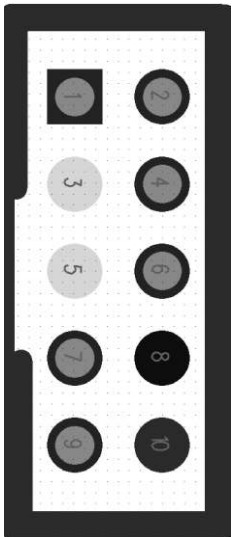
Connector	Description	Remark																				
9	<p data-bbox="443 193 824 220">Head open sensor connector</p>  <table border="1" data-bbox="736 225 1249 456"> <thead> <tr> <th data-bbox="745 231 909 272">Pin</th> <th data-bbox="909 231 1240 272">Description</th> </tr> </thead> <tbody> <tr> <td data-bbox="745 272 909 314">1</td> <td data-bbox="909 272 1240 314">HEAD open</td> </tr> <tr> <td data-bbox="745 314 909 355">2</td> <td data-bbox="909 314 1240 355">GND</td> </tr> <tr> <td data-bbox="745 355 909 397">3</td> <td data-bbox="909 355 1240 397">3.3V</td> </tr> <tr> <td data-bbox="745 397 909 456">4</td> <td data-bbox="909 397 1240 456">3.3V</td> </tr> </tbody> </table>	Pin	Description	1	HEAD open	2	GND	3	3.3V	4	3.3V	CON1										
Pin	Description																					
1	HEAD open																					
2	GND																					
3	3.3V																					
4	3.3V																					
10	<p data-bbox="443 663 1021 691">LCD panel (Interface 1, SPI LCD) connector</p>  <table border="1" data-bbox="871 695 1456 1294"> <thead> <tr> <th data-bbox="880 702 1043 759">Pin</th> <th data-bbox="1043 702 1447 759">Description</th> </tr> </thead> <tbody> <tr> <td data-bbox="880 759 1043 817">1</td> <td data-bbox="1043 759 1447 817">3.3V</td> </tr> <tr> <td data-bbox="880 817 1043 874">2</td> <td data-bbox="1043 817 1447 874">LCD_SI</td> </tr> <tr> <td data-bbox="880 874 1043 932">3</td> <td data-bbox="1043 874 1447 932">LCD_SCL</td> </tr> <tr> <td data-bbox="880 932 1043 989">4</td> <td data-bbox="1043 932 1447 989">LCD_CS1</td> </tr> <tr> <td data-bbox="880 989 1043 1046">5</td> <td data-bbox="1043 989 1447 1046">SLCD_D/CX</td> </tr> <tr> <td data-bbox="880 1046 1043 1104">6</td> <td data-bbox="1043 1046 1447 1104">LCD_BL</td> </tr> <tr> <td data-bbox="880 1104 1043 1161">7</td> <td data-bbox="1043 1104 1447 1161">SLCD_RESET</td> </tr> <tr> <td data-bbox="880 1161 1043 1219">8</td> <td data-bbox="1043 1161 1447 1219">GND</td> </tr> <tr> <td data-bbox="880 1219 1043 1294">9</td> <td data-bbox="1043 1219 1447 1294">5V</td> </tr> </tbody> </table>	Pin	Description	1	3.3V	2	LCD_SI	3	LCD_SCL	4	LCD_CS1	5	SLCD_D/CX	6	LCD_BL	7	SLCD_RESET	8	GND	9	5V	CON23
Pin	Description																					
1	3.3V																					
2	LCD_SI																					
3	LCD_SCL																					
4	LCD_CS1																					
5	SLCD_D/CX																					
6	LCD_BL																					
7	SLCD_RESET																					
8	GND																					
9	5V																					

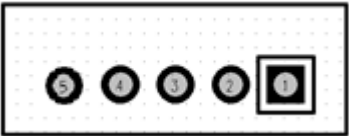
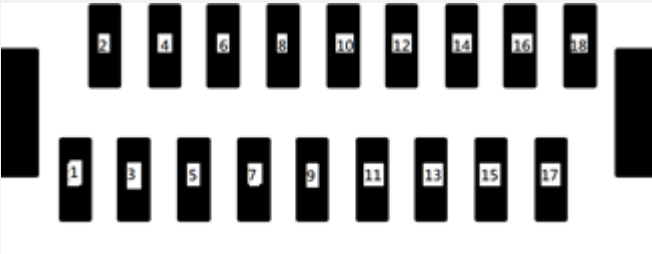
Connector	Description	Remark																						
11	<p data-bbox="443 180 689 212">SD card connector</p>  <table border="1" data-bbox="871 212 1458 810"> <thead> <tr> <th data-bbox="882 220 1039 268">Pin</th> <th data-bbox="1039 220 1447 268">Description</th> </tr> </thead> <tbody> <tr> <td data-bbox="882 276 1039 323">1</td> <td data-bbox="1039 276 1447 323">3.3V</td> </tr> <tr> <td data-bbox="882 331 1039 379">2</td> <td data-bbox="1039 331 1447 379">MIC0_DA0</td> </tr> <tr> <td data-bbox="882 387 1039 435">3</td> <td data-bbox="1039 387 1447 435">MIC0_DA1</td> </tr> <tr> <td data-bbox="882 443 1039 491">4</td> <td data-bbox="1039 443 1447 491">MIC0_DA2</td> </tr> <tr> <td data-bbox="882 499 1039 547">5</td> <td data-bbox="1039 499 1447 547">MIC0_DA3</td> </tr> <tr> <td data-bbox="882 555 1039 603">6</td> <td data-bbox="1039 555 1447 603">MIC0_CK</td> </tr> <tr> <td data-bbox="882 611 1039 659">7</td> <td data-bbox="1039 611 1447 659">MIC0_CMD</td> </tr> <tr> <td data-bbox="882 667 1039 715">8</td> <td data-bbox="1039 667 1447 715">Micro_SD_DATA2</td> </tr> <tr> <td data-bbox="882 722 1039 770">9</td> <td data-bbox="1039 722 1447 770">SD_Detect</td> </tr> </tbody> </table>	Pin	Description	1	3.3V	2	MIC0_DA0	3	MIC0_DA1	4	MIC0_DA2	5	MIC0_DA3	6	MIC0_CK	7	MIC0_CMD	8	Micro_SD_DATA2	9	SD_Detect	CON3		
Pin	Description																							
1	3.3V																							
2	MIC0_DA0																							
3	MIC0_DA1																							
4	MIC0_DA2																							
5	MIC0_DA3																							
6	MIC0_CK																							
7	MIC0_CMD																							
8	Micro_SD_DATA2																							
9	SD_Detect																							
12	<p data-bbox="443 842 651 874">Wi-Fi connector</p>  <table border="1" data-bbox="871 871 1458 1442"> <thead> <tr> <th data-bbox="882 879 1039 927">Pin</th> <th data-bbox="1039 879 1447 927">Description</th> </tr> </thead> <tbody> <tr> <td data-bbox="882 935 1039 983">1</td> <td data-bbox="1039 935 1447 983">3.3V</td> </tr> <tr> <td data-bbox="882 991 1039 1038">2</td> <td data-bbox="1039 991 1447 1038">RESET</td> </tr> <tr> <td data-bbox="882 1046 1039 1094">3</td> <td data-bbox="1039 1046 1447 1094">SPI_MISO</td> </tr> <tr> <td data-bbox="882 1102 1039 1150">4</td> <td data-bbox="1039 1102 1447 1150">RTS</td> </tr> <tr> <td data-bbox="882 1158 1039 1206">5</td> <td data-bbox="1039 1158 1447 1206">SPI_MOSI</td> </tr> <tr> <td data-bbox="882 1214 1039 1262">6</td> <td data-bbox="1039 1214 1447 1262">CTS</td> </tr> <tr> <td data-bbox="882 1270 1039 1318">7</td> <td data-bbox="1039 1270 1447 1318">SPI_INTR</td> </tr> <tr> <td data-bbox="882 1326 1039 1374">8</td> <td data-bbox="1039 1326 1447 1374">SPI_CLK</td> </tr> <tr> <td data-bbox="882 1382 1039 1430">9</td> <td data-bbox="1039 1382 1447 1430">WB_GPIO</td> </tr> <tr> <td data-bbox="882 1437 1039 1485">10</td> <td data-bbox="1039 1437 1447 1485">GND</td> </tr> </tbody> </table>	Pin	Description	1	3.3V	2	RESET	3	SPI_MISO	4	RTS	5	SPI_MOSI	6	CTS	7	SPI_INTR	8	SPI_CLK	9	WB_GPIO	10	GND	CON28
Pin	Description																							
1	3.3V																							
2	RESET																							
3	SPI_MISO																							
4	RTS																							
5	SPI_MOSI																							
6	CTS																							
7	SPI_INTR																							
8	SPI_CLK																							
9	WB_GPIO																							
10	GND																							

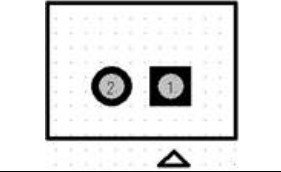
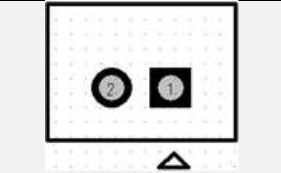
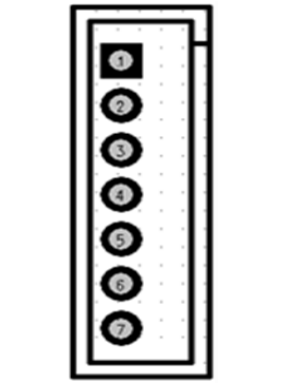
Connector	Description	Remark																																						
13	Micro processor	-																																						
14	Liner rewinder connector  <table border="1" data-bbox="875 252 1458 563"> <thead> <tr> <th>Pin</th> <th>Description</th> </tr> </thead> <tbody> <tr> <td>1</td> <td>3.3V</td> </tr> <tr> <td>2</td> <td>24V</td> </tr> <tr> <td>3</td> <td>GND</td> </tr> <tr> <td>4</td> <td>PWM</td> </tr> <tr> <td>5</td> <td>PHASE</td> </tr> </tbody> </table>	Pin	Description	1	3.3V	2	24V	3	GND	4	PWM	5	PHASE	CON26																										
Pin	Description																																							
1	3.3V																																							
2	24V																																							
3	GND																																							
4	PWM																																							
5	PHASE																																							
15	LCD panel (Interface 2, parallel LCD) connector  <table border="1" data-bbox="1155 627 1552 1431"> <thead> <tr> <th>Pin</th> <th>Description</th> </tr> </thead> <tbody> <tr> <td>1</td> <td>5V</td> </tr> <tr> <td>2</td> <td>5V</td> </tr> <tr> <td>3</td> <td>GND</td> </tr> <tr> <td>4</td> <td>3.3V</td> </tr> <tr> <td>5</td> <td>LCD_BL</td> </tr> <tr> <td>6</td> <td>LCD_D/CX</td> </tr> <tr> <td>7</td> <td>LCD_D0</td> </tr> <tr> <td>8</td> <td>LCD_D1</td> </tr> <tr> <td>9</td> <td>LCD_D2</td> </tr> <tr> <td>10</td> <td>LCD_D3</td> </tr> <tr> <td>11</td> <td>LCD_D4</td> </tr> <tr> <td>12</td> <td>LCD_D5</td> </tr> <tr> <td>13</td> <td>LCD_D6</td> </tr> <tr> <td>14</td> <td>LCD_D7</td> </tr> <tr> <td>15</td> <td>LCD_NCS</td> </tr> <tr> <td>16</td> <td>LCD_RESET</td> </tr> <tr> <td>17</td> <td>LCD_WE</td> </tr> <tr> <td>18</td> <td>GND</td> </tr> </tbody> </table>	Pin	Description	1	5V	2	5V	3	GND	4	3.3V	5	LCD_BL	6	LCD_D/CX	7	LCD_D0	8	LCD_D1	9	LCD_D2	10	LCD_D3	11	LCD_D4	12	LCD_D5	13	LCD_D6	14	LCD_D7	15	LCD_NCS	16	LCD_RESET	17	LCD_WE	18	GND	CON9
Pin	Description																																							
1	5V																																							
2	5V																																							
3	GND																																							
4	3.3V																																							
5	LCD_BL																																							
6	LCD_D/CX																																							
7	LCD_D0																																							
8	LCD_D1																																							
9	LCD_D2																																							
10	LCD_D3																																							
11	LCD_D4																																							
12	LCD_D5																																							
13	LCD_D6																																							
14	LCD_D7																																							
15	LCD_NCS																																							
16	LCD_RESET																																							
17	LCD_WE																																							
18	GND																																							

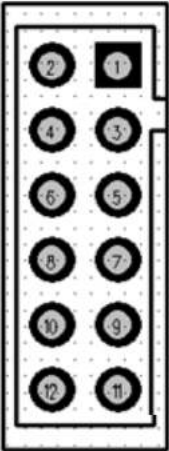
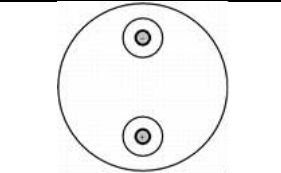
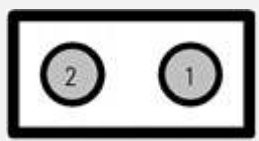
Connector	Description	Remark																
16	<p>Gap receiver sensor connector</p>  <table border="1" data-bbox="741 228 1249 400"> <thead> <tr> <th data-bbox="741 228 909 272">Pin</th> <th data-bbox="909 228 1249 272">Description</th> </tr> </thead> <tbody> <tr> <td data-bbox="741 272 909 339">1</td> <td data-bbox="909 272 1249 339">Gap sensor receiver</td> </tr> <tr> <td data-bbox="741 339 909 400">2</td> <td data-bbox="909 339 1249 400">3.3V</td> </tr> </tbody> </table>	Pin	Description	1	Gap sensor receiver	2	3.3V	CON5										
Pin	Description																	
1	Gap sensor receiver																	
2	3.3V																	
17	<p>Gap emitter sensor connector</p>  <table border="1" data-bbox="741 510 1249 683"> <thead> <tr> <th data-bbox="741 510 909 555">Pin</th> <th data-bbox="909 510 1249 555">Description</th> </tr> </thead> <tbody> <tr> <td data-bbox="741 555 909 622">1</td> <td data-bbox="909 555 1249 622">Gap sensor emitter</td> </tr> <tr> <td data-bbox="741 622 909 683">2</td> <td data-bbox="909 622 1249 683">3.3V</td> </tr> </tbody> </table>	Pin	Description	1	Gap sensor emitter	2	3.3V	CON20										
Pin	Description																	
1	Gap sensor emitter																	
2	3.3V																	
18	<p>RFID connector</p>  <table border="1" data-bbox="741 794 1249 1182"> <thead> <tr> <th data-bbox="741 794 909 839">Pin</th> <th data-bbox="909 794 1249 839">Description</th> </tr> </thead> <tbody> <tr> <td data-bbox="741 839 909 884">1</td> <td data-bbox="909 839 1249 884">5V</td> </tr> <tr> <td data-bbox="741 884 909 928">2</td> <td data-bbox="909 884 1249 928">RX</td> </tr> <tr> <td data-bbox="741 928 909 973">3</td> <td data-bbox="909 928 1249 973">TX</td> </tr> <tr> <td data-bbox="741 973 909 1018">4</td> <td data-bbox="909 973 1249 1018">RX</td> </tr> <tr> <td data-bbox="741 1018 909 1062">5</td> <td data-bbox="909 1018 1249 1062">TX</td> </tr> <tr> <td data-bbox="741 1062 909 1107">6</td> <td data-bbox="909 1062 1249 1107">GND</td> </tr> <tr> <td data-bbox="741 1107 909 1182">7</td> <td data-bbox="909 1107 1249 1182">GND</td> </tr> </tbody> </table>	Pin	Description	1	5V	2	RX	3	TX	4	RX	5	TX	6	GND	7	GND	CON8
Pin	Description																	
1	5V																	
2	RX																	
3	TX																	
4	RX																	
5	TX																	
6	GND																	
7	GND																	

Connector	Description	Remark																										
19	<p>Wi-Fi / Bluetooth connector</p>  <table border="1" data-bbox="741 220 1249 898"> <thead> <tr> <th>Pin</th> <th>Description</th> </tr> </thead> <tbody> <tr><td>1</td><td>3.3V</td></tr> <tr><td>2</td><td>MDC</td></tr> <tr><td>3</td><td>MDIO</td></tr> <tr><td>4</td><td>CRSDV</td></tr> <tr><td>5</td><td>GRX0</td></tr> <tr><td>6</td><td>RXER</td></tr> <tr><td>7</td><td>RX1</td></tr> <tr><td>8</td><td>TXEN</td></tr> <tr><td>9</td><td>REFCK</td></tr> <tr><td>10</td><td>TX1</td></tr> <tr><td>11</td><td>GND</td></tr> <tr><td>12</td><td>TX0</td></tr> </tbody> </table>	Pin	Description	1	3.3V	2	MDC	3	MDIO	4	CRSDV	5	GRX0	6	RXER	7	RX1	8	TXEN	9	REFCK	10	TX1	11	GND	12	TX0	CON13
Pin	Description																											
1	3.3V																											
2	MDC																											
3	MDIO																											
4	CRSDV																											
5	GRX0																											
6	RXER																											
7	RX1																											
8	TXEN																											
9	REFCK																											
10	TX1																											
11	GND																											
12	TX0																											
20	<p>Buzzer</p>  <table border="1" data-bbox="741 994 1249 1166"> <thead> <tr> <th>Pin</th> <th>Description</th> </tr> </thead> <tbody> <tr><td>+</td><td>SYS 24V</td></tr> <tr><td>-</td><td>Buzzer control</td></tr> </tbody> </table>	Pin	Description	+	SYS 24V	-	Buzzer control	BZ1																				
Pin	Description																											
+	SYS 24V																											
-	Buzzer control																											
21 & 26	<p>ESD cable connector</p>  <table border="1" data-bbox="741 1270 1249 1442"> <thead> <tr> <th>Pin</th> <th>Description</th> </tr> </thead> <tbody> <tr><td>1</td><td>GND</td></tr> <tr><td>2</td><td>GND</td></tr> </tbody> </table>	Pin	Description	1	GND	2	GND	JP1 & JP2																				
Pin	Description																											
1	GND																											
2	GND																											

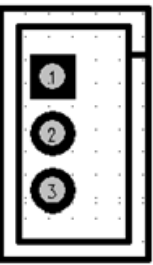
Connector	Description	Remark										
22	<p>Ribbon end sensor connector</p>  <table border="1" data-bbox="797 213 1361 504"> <thead> <tr> <th data-bbox="797 213 909 272">Pin</th> <th data-bbox="909 213 1361 272">Description</th> </tr> </thead> <tbody> <tr> <td data-bbox="797 272 909 331">1</td> <td data-bbox="909 272 1361 331">RIB sensor receiver</td> </tr> <tr> <td data-bbox="797 331 909 391">2</td> <td data-bbox="909 331 1361 391">3.3V</td> </tr> <tr> <td data-bbox="797 391 909 450">3</td> <td data-bbox="909 391 1361 450">GND</td> </tr> <tr> <td data-bbox="797 450 909 504">4</td> <td data-bbox="909 450 1361 504">RIB sensor emitter</td> </tr> </tbody> </table>	Pin	Description	1	RIB sensor receiver	2	3.3V	3	GND	4	RIB sensor emitter	CON11
Pin	Description											
1	RIB sensor receiver											
2	3.3V											
3	GND											
4	RIB sensor emitter											
23	<p>Ribbon encoder sensor connector</p>  <table border="1" data-bbox="797 592 1361 882"> <thead> <tr> <th data-bbox="797 592 909 651">Pin</th> <th data-bbox="909 592 1361 651">Description</th> </tr> </thead> <tbody> <tr> <td data-bbox="797 651 909 710">1</td> <td data-bbox="909 651 1361 710">3.3V</td> </tr> <tr> <td data-bbox="797 710 909 769">2</td> <td data-bbox="909 710 1361 769">RIB encoder sensor receiver</td> </tr> <tr> <td data-bbox="797 769 909 828">3</td> <td data-bbox="909 769 1361 828">GND</td> </tr> <tr> <td data-bbox="797 828 909 882">4</td> <td data-bbox="909 828 1361 882">GND</td> </tr> </tbody> </table>	Pin	Description	1	3.3V	2	RIB encoder sensor receiver	3	GND	4	GND	CON12
Pin	Description											
1	3.3V											
2	RIB encoder sensor receiver											
3	GND											
4	GND											
24	<p>Black mark sensor connector</p>  <table border="1" data-bbox="797 1058 1361 1331"> <thead> <tr> <th data-bbox="797 1058 909 1129">Pin</th> <th data-bbox="909 1058 1361 1129">Description</th> </tr> </thead> <tbody> <tr> <td data-bbox="797 1129 909 1193">1</td> <td data-bbox="909 1129 1361 1193">BM sensor emitter</td> </tr> <tr> <td data-bbox="797 1193 909 1257">2</td> <td data-bbox="909 1193 1361 1257">BM sensor receiver</td> </tr> <tr> <td data-bbox="797 1257 909 1331">3</td> <td data-bbox="909 1257 1361 1331">3.3V</td> </tr> </tbody> </table>	Pin	Description	1	BM sensor emitter	2	BM sensor receiver	3	3.3V	CON21		
Pin	Description											
1	BM sensor emitter											
2	BM sensor receiver											
3	3.3V											

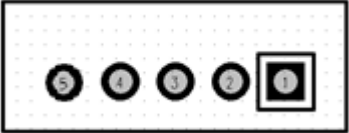
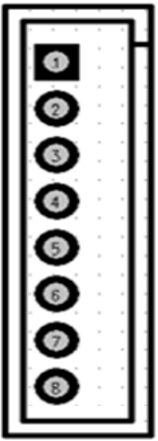
Connector	Description	Remark																		
25	<p>Peel-off/ GPIO sensor connector</p>  <table border="1" data-bbox="871 261 1494 609"> <thead> <tr> <th>Pin</th> <th>Description</th> </tr> </thead> <tbody> <tr> <td>1</td> <td>GND</td> </tr> <tr> <td>2</td> <td>Vout</td> </tr> <tr> <td>3</td> <td>SDA</td> </tr> <tr> <td>4</td> <td>SCL</td> </tr> <tr> <td>5</td> <td>3.3V</td> </tr> </tbody> </table>	Pin	Description	1	GND	2	Vout	3	SDA	4	SCL	5	3.3V	CON10						
Pin	Description																			
1	GND																			
2	Vout																			
3	SDA																			
4	SCL																			
5	3.3V																			
27	<p>Cutter/ GPIO connector</p>  <table border="1" data-bbox="741 748 1249 1201"> <thead> <tr> <th>Pin</th> <th>Description</th> </tr> </thead> <tbody> <tr> <td>1</td> <td>24V</td> </tr> <tr> <td>2</td> <td>Cutter PL</td> </tr> <tr> <td>3</td> <td>Cutter PHASE</td> </tr> <tr> <td>4</td> <td>Cutter EN</td> </tr> <tr> <td>5</td> <td>Cutter STATE</td> </tr> <tr> <td>6</td> <td>GND</td> </tr> <tr> <td>7</td> <td>5V</td> </tr> <tr> <td>8</td> <td>GPIO_INT</td> </tr> </tbody> </table>	Pin	Description	1	24V	2	Cutter PL	3	Cutter PHASE	4	Cutter EN	5	Cutter STATE	6	GND	7	5V	8	GPIO_INT	CON6
Pin	Description																			
1	24V																			
2	Cutter PL																			
3	Cutter PHASE																			
4	Cutter EN																			
5	Cutter STATE																			
6	GND																			
7	5V																			
8	GPIO_INT																			

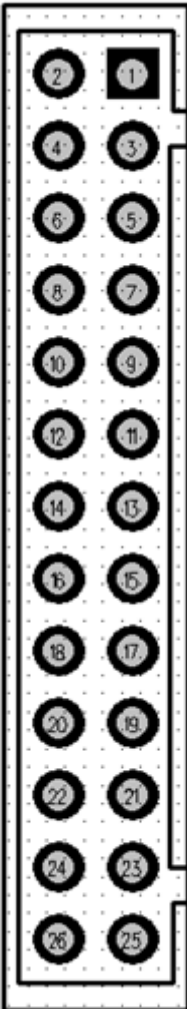
Connector	Description		Remark																																																						
28	Printhead connector		CON24																																																						
		<table border="1"> <thead> <tr> <th data-bbox="842 188 983 233">Pin</th> <th data-bbox="983 188 1547 233">Description</th> </tr> </thead> <tbody> <tr><td>1</td><td>TPH 24V</td></tr> <tr><td>2</td><td>TPH 24V</td></tr> <tr><td>3</td><td>TPH 24V</td></tr> <tr><td>4</td><td>TPH 24V</td></tr> <tr><td>5</td><td>GND</td></tr> <tr><td>6</td><td>GND</td></tr> <tr><td>7</td><td>Strobe2</td></tr> <tr><td>8</td><td>Data2</td></tr> <tr><td>9</td><td>TPH ID</td></tr> <tr><td>10</td><td>Temperature sensor</td></tr> <tr><td>11</td><td>5V</td></tr> <tr><td>12</td><td>GND</td></tr> <tr><td>13</td><td>Strobe1</td></tr> <tr><td>14</td><td>GND</td></tr> <tr><td>15</td><td>Clock</td></tr> <tr><td>16</td><td>GND</td></tr> <tr><td>17</td><td>GND</td></tr> <tr><td>18</td><td>GND</td></tr> <tr><td>19</td><td>Data1</td></tr> <tr><td>20</td><td>Latch</td></tr> <tr><td>21</td><td>GND</td></tr> <tr><td>22</td><td>GND</td></tr> <tr><td>23</td><td>TPH 24V</td></tr> <tr><td>24</td><td>TPH 24V</td></tr> <tr><td>25</td><td>TPH 24V</td></tr> <tr><td>26</td><td>TPH 24V</td></tr> </tbody> </table>		Pin	Description	1	TPH 24V	2	TPH 24V	3	TPH 24V	4	TPH 24V	5	GND	6	GND	7	Strobe2	8	Data2	9	TPH ID	10	Temperature sensor	11	5V	12	GND	13	Strobe1	14	GND	15	Clock	16	GND	17	GND	18	GND	19	Data1	20	Latch	21	GND	22	GND	23	TPH 24V	24	TPH 24V	25	TPH 24V	26	TPH 24V
	Pin	Description																																																							
	1	TPH 24V																																																							
	2	TPH 24V																																																							
	3	TPH 24V																																																							
	4	TPH 24V																																																							
	5	GND																																																							
	6	GND																																																							
	7	Strobe2																																																							
	8	Data2																																																							
	9	TPH ID																																																							
	10	Temperature sensor																																																							
	11	5V																																																							
	12	GND																																																							
	13	Strobe1																																																							
	14	GND																																																							
	15	Clock																																																							
	16	GND																																																							
	17	GND																																																							
	18	GND																																																							
	19	Data1																																																							
	20	Latch																																																							
	21	GND																																																							
	22	GND																																																							
	23	TPH 24V																																																							
24	TPH 24V																																																								
25	TPH 24V																																																								
26	TPH 24V																																																								

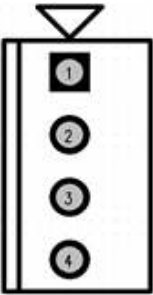
Connector	Description	Remark										
29	<p data-bbox="443 209 786 240">Stepping motor connector</p> <table border="1" data-bbox="450 240 1361 555"> <thead> <tr> <th data-bbox="450 240 792 288">Pin</th> <th data-bbox="792 240 1361 288">Description</th> </tr> </thead> <tbody> <tr> <td data-bbox="450 288 792 357">1</td> <td data-bbox="792 288 1361 357">BOUT2</td> </tr> <tr> <td data-bbox="450 357 792 426">2</td> <td data-bbox="792 357 1361 426">BOUT1</td> </tr> <tr> <td data-bbox="450 426 792 494">3</td> <td data-bbox="792 426 1361 494">AOUT1</td> </tr> <tr> <td data-bbox="450 494 792 555">4</td> <td data-bbox="792 494 1361 555">AOUT2</td> </tr> </tbody> </table> 	Pin	Description	1	BOUT2	2	BOUT1	3	AOUT1	4	AOUT2	CON16
Pin	Description											
1	BOUT2											
2	BOUT1											
3	AOUT1											
4	AOUT2											

2.2 Interface Pin Configuration

■ RS-232C

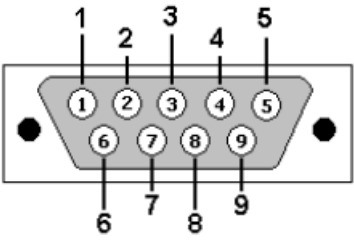
	Pin	Description
	1	+5 V
	2	TXD
	3	RXD
	4	CTS
	5	GND
	6	RTS
	7	N/C
	8	RTS
	9	N/C

■ USB Device

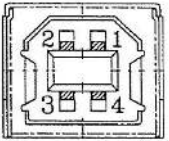
	Pin	Description
	1	N/C
	2	D-
	3	D+
	4	GND

■ USB Host

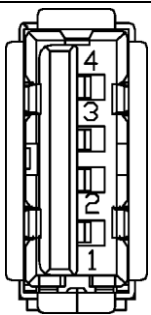
	Pin	Description
	1	5V
	2	D-
	3	D+
	4	GND

■ Ethernet

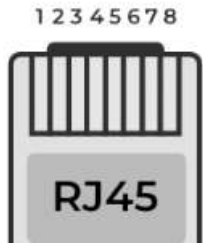
	Pin	Description
	1	Tx+
	2	Tx-
	3	Rx+
	4	N/C
	5	N/C
	6	Rx-
	7	N/C
8	N/C	

■ Cutter/peel-off Sensor Connector

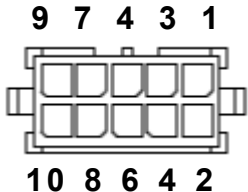
	Pin	Description	Voltage
	1	Cutter enable	0V: Cutter work 5V: Cutter stop
	2	Cutter direction	0V: Cutter positive cut 5V: Cutter negative cut
	3	Cutter position sensor switch	0V: Cutter stop 3.3V: Cutter work
	4	Peel sensor receiver	A/D: 0~3.3V
	5	N/A	N/A
	6	Logic power	5V
	7	GND	0V
	8	Cutter power	24V
	9	I2C SCL signal	
10	I2C SDA signal		

3. Replacing Parts

3.1 Before You Begin

WARNING:

To avoid the risk of personal injury from electrical shock, before performing any replacement procedures, unplug the power cord from the printer or power outlet to ensure that power is removed.

To prepare the printer for the replacement or installation:

1. Protect yourself from ESD and wear protective gloves.
2. Place the printer on a flat surface.
3. Set the printer's power switch to the O (Off) position.
4. Remove the power cord from the printer or unplug the power cord from the AC power outlet.
5. Disconnect all interface cables from the rear panel of the printer.
6. Remove the media and ribbon from the printer.
7. Read through the maintenance procedures.

3.2 Removing the Lower Front Panel

1. Follow the steps in [Before You Begin](#) to prepare the printer.
2. Raise the media cover. Push the printhead release lever to open the printhead mechanism.
3. Move the tab outward then pull the panel inward to remove the lower front panel.

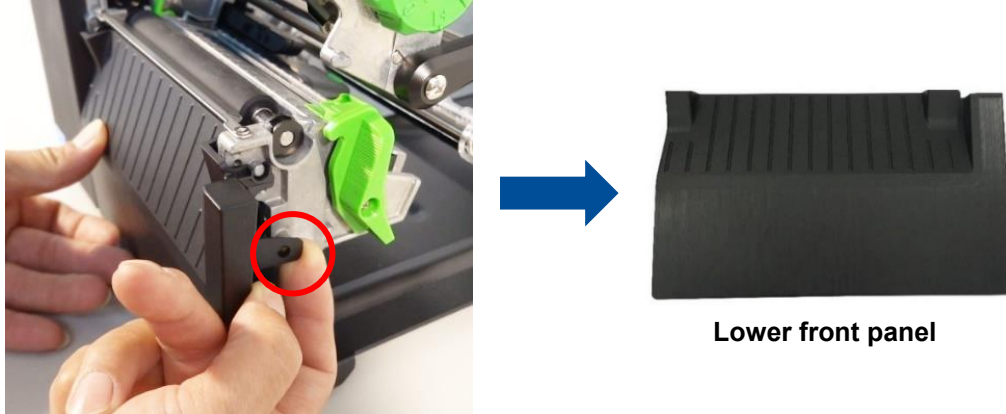

4. Reassemble the parts in the reverse procedures.

Note: When install the lower front panel, please attach the hook along the protrusion of print head mechanism.

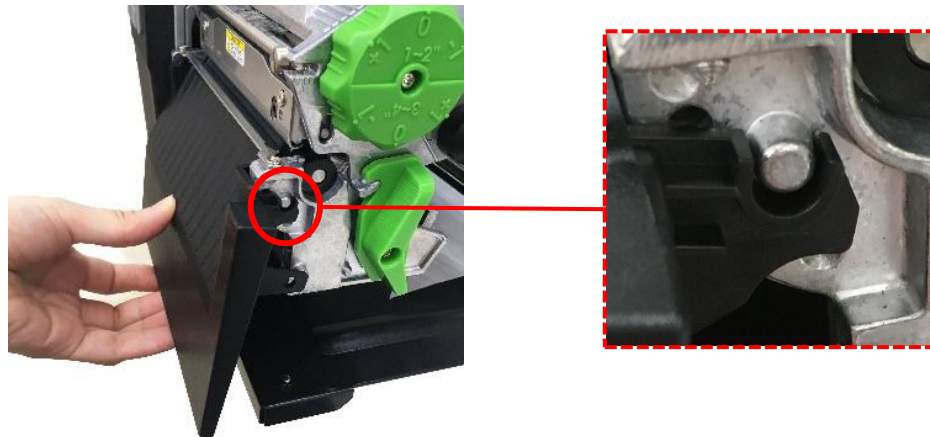

3.3 Removing the Electronics Cover

1. Follow the steps in [Before You Begin](#) to prepare the printer.
2. Raise the media cover and remove the two screws (fastened by $7.5 \text{ kg} \pm 15\% \text{ kg-cm}$) on the inside of the printer as indicated.
3. Remove the two screws (fastened by $7.5 \text{ kg} \pm 15\% \text{ kg-cm}$) securing the side cover (electronic cover) to the printer frame.

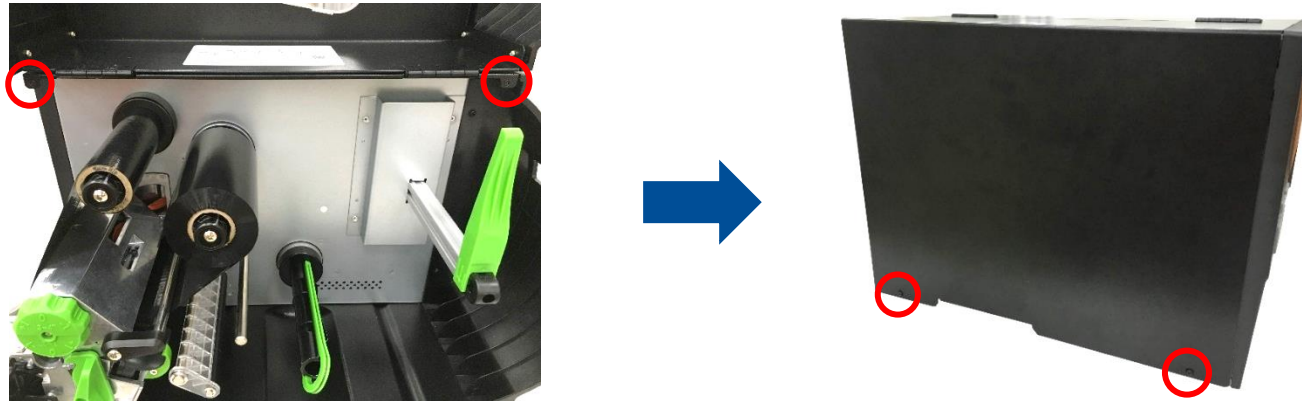

4. From the back of the printer lift up and tilt the top of the side cover up until the tabs along the lower edge disengage from the slots in the printer base frame and remove the side cover.



5. Reassemble the parts in the reverse procedures.

3.4 Replacing the Platen Roller Assembly

1. Follow the steps in [Before You Begin](#) to prepare the printer.
2. Refer to [Removing the Lower Front Panel](#) to remove the lower front panel.
3. Disengage the platen roller by pulling out the tabs located on both sides. Rotate the tabs into the end of mechanism as shown. Pulling upward to remove/replace the platen roller assembly.

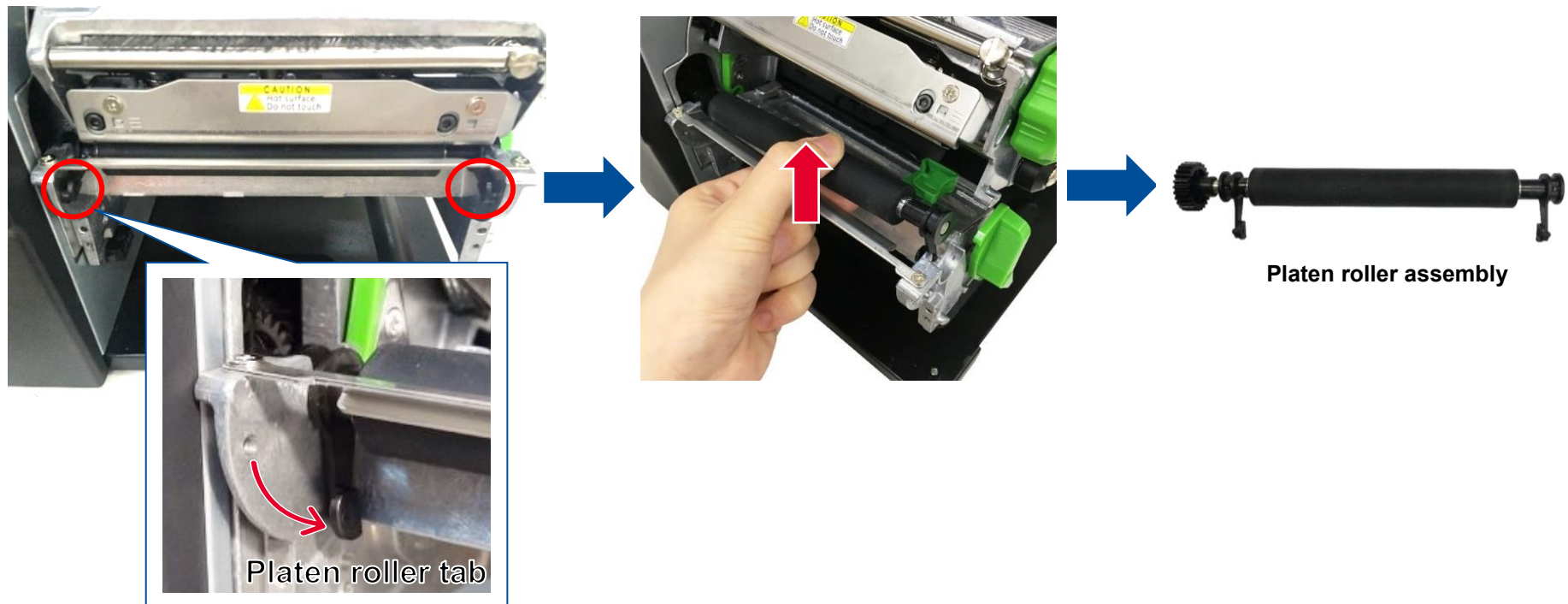

4. Reassemble the parts in the reverse procedures.

3.5 Replacing the Printhead Assembly

CAUTION:

To prevent electrostatic damage to electronic components, ground yourself by touching an unpainted part of the printer frame before removing or installing the printhead assembly.

1. Follow the steps in [Before You Begin](#) to prepare the printer.
2. Raise the media cover.
3. Push the printhead release lever to open the printhead mechanism.
4. Remove a screw (fastened by $5\text{ kg}\pm 15\% \text{ kg-cm}$) securing the printhead to the deck as indicated.

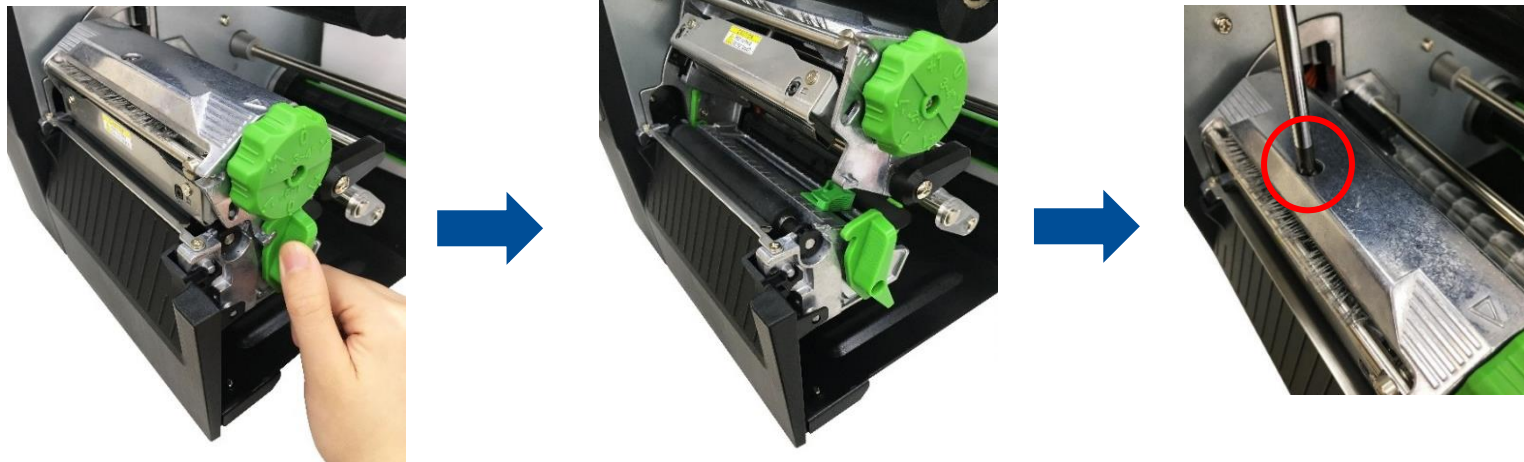

5. Disconnect the printhead harness to remove/replace the new printhead assembly.

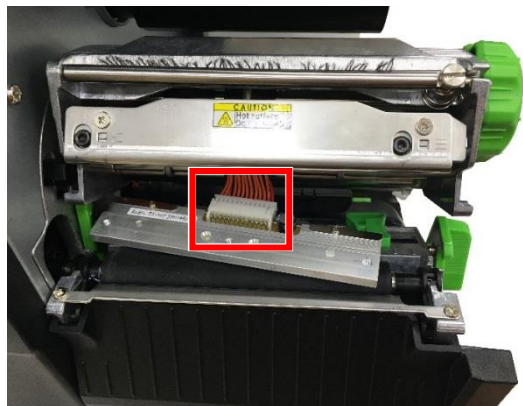

Note:

Use the new printhead screw to install the new printhead assembly.

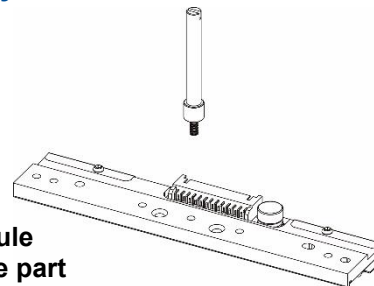

**Printhead module
assembly spare part**

6. Reassemble the parts in the reverse procedures.

3.6 Replacing the Control Panel Assembly

1. Follow the steps in [Before You Begin](#) to prepare the printer.
2. Refer to [Removing the Electronics Cover](#) to remove the electronics cover.
3. Remove one screw (3.5" touch panel: fastened by 3.5 kg±15% kg-cm; 2.3" LCD panel: fastened by 3.5 kg±15% kg-cm) at the bottom of the control panel as shown then disengage the rectangular locking tab at the top of the control panel. Disconnect two connectors on control panel board.

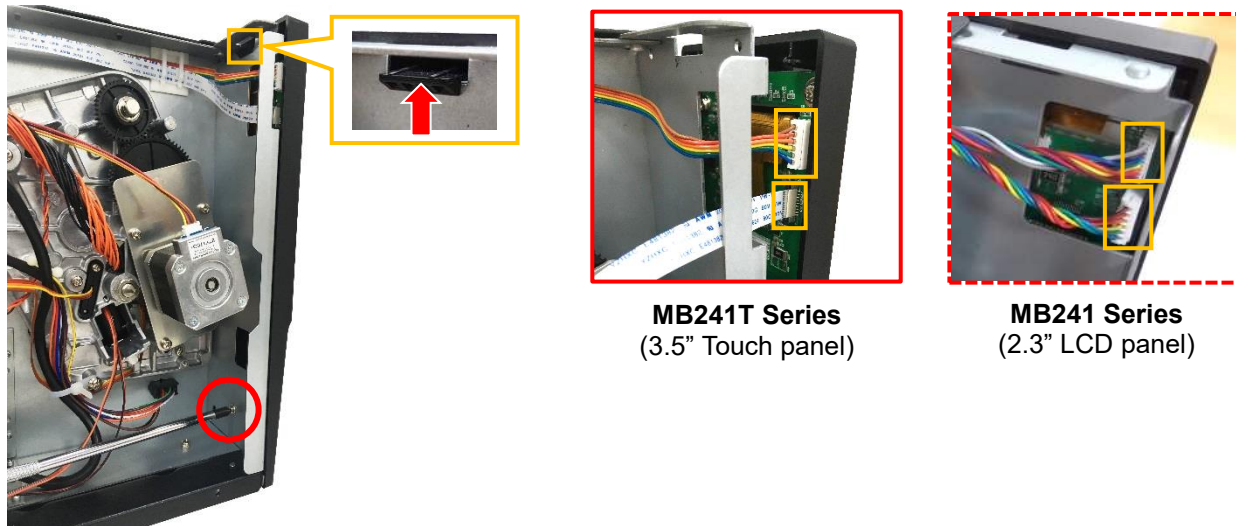

4. Remove/Replace the control panel assembly.
5. Reassemble the parts in the reverse procedures.

Note:

When reassemble the parts, please install the cables through the loading path as indicated.



3.7 Replacing the Main Board

1. Follow the steps in [Before You Begin](#) to prepare the printer.
2. Refer to [Removing the Electronics Cover](#) to remove the electronics cover.
3. Refer to [Slot-in Wireless Housing Installation \(Option\)](#) to remove the wireless housing. (if module installed)
Refer to [GPIO Interface Assembly Installation \(Option\)](#) to remove the GPIO interface board. (if module installed)
4. Remove two screws and two hexagon screws (RS-232) on the rear of printer.
Remove four screws (fastened by 7.5 kg±15% kg-cm) and disconnect all the connectors from the main board.

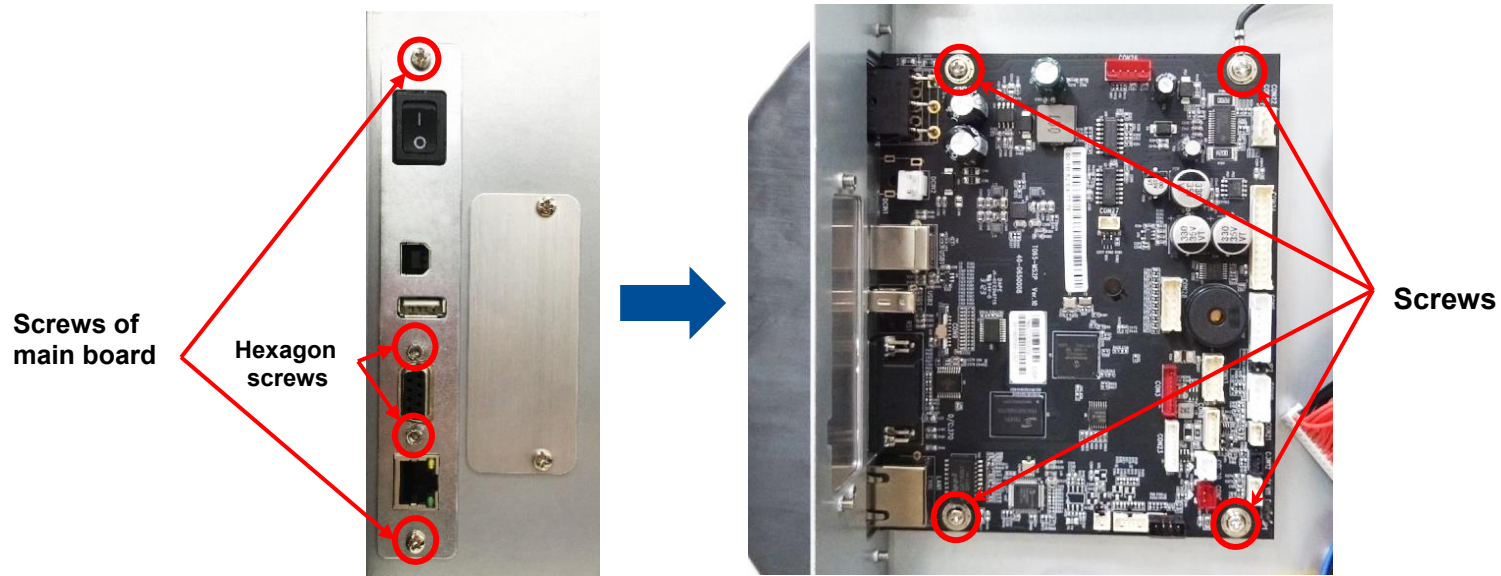

5. Remove/Replace the main board.
6. Reassemble the parts in the reverse procedures.

3.8 Replacing the Label Supply Spindle

1. Follow the steps in [Before You Begin](#) to prepare the printer.
2. Refer to [Removing the Electronics Cover](#) to remove the electronics cover.
3. Refer to [Replacing the Main Board](#) to remove the main board.
4. After removing the main board, loosen two screws (fastened by $7.5 \text{ kg} \pm 15\% \text{ kg-cm}$) as indicated. Remove/Replace the label supply spindle.

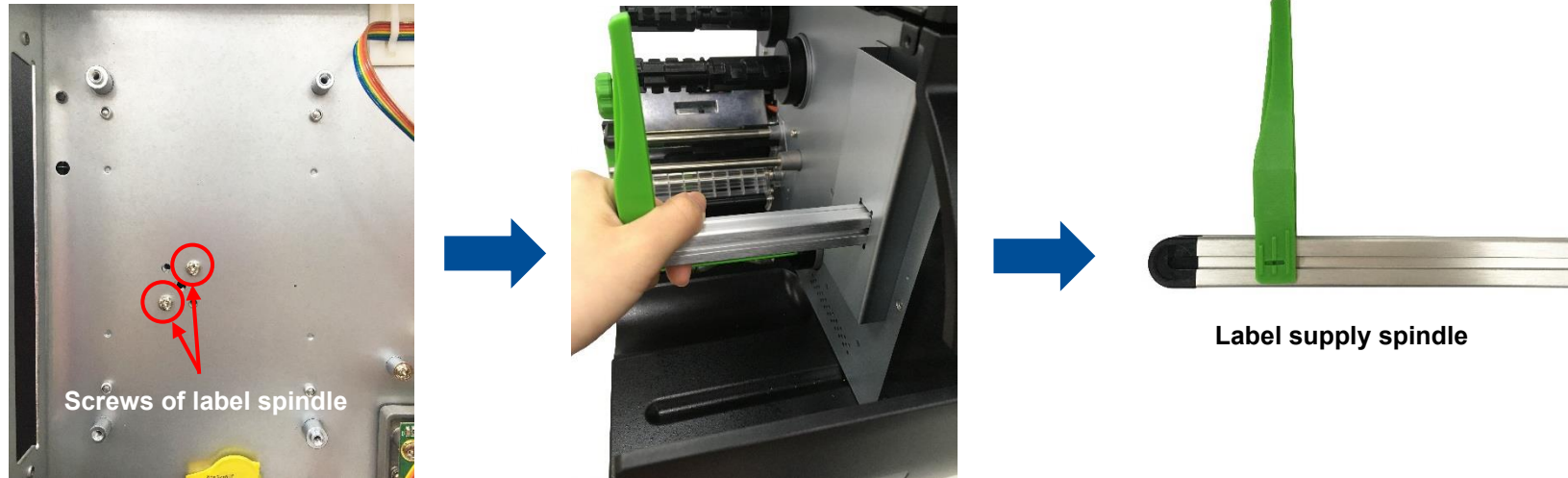

5. Reassemble the parts in the reverse procedures.

3.9 Replacing the Power Supply Unit

1. Follow the steps in [Before You Begin](#) to prepare the printer.
2. Refer to [Removing the Electronics Cover](#) to remove the electronics cover.
3. Remove three screws (fastened by $7.5 \text{ kg} \pm 15\% \text{ kg-cm}$) as indicated below.



4. Remove one screw (fastened by $7.5 \text{ kg} \pm 15\% \text{ kg-cm}$) and disconnect one connector on main board. Loosen three cable ties to remove/replace the power supply unit.

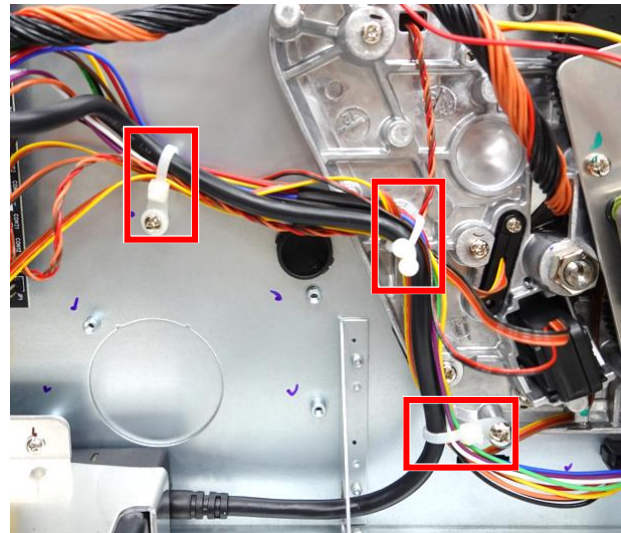
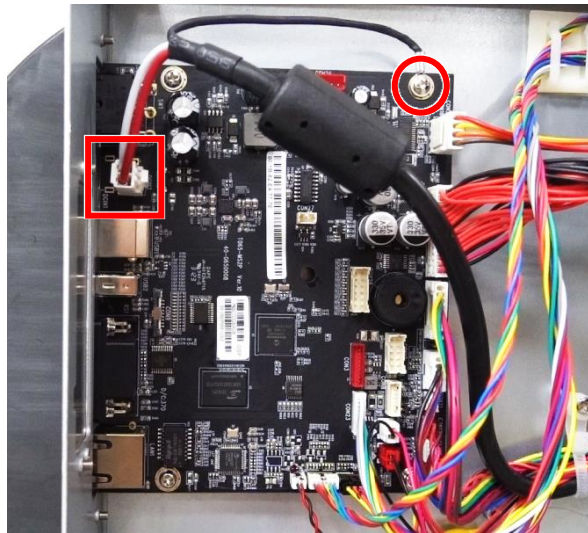

5. Reassemble the parts in the reverse procedure.

3.10 Replacing the Stepping Motor Assembly

1. Follow the steps in [Before You Begin](#) to prepare the printer.
2. Refer to [Removing the Electronics Cover](#) to remove the electronics cover.
3. Disconnect one connector on the main board and loosen one cable tie.

Remove four screws (fastened by $10.5 \text{ kg} \pm 15\% \text{ kg-cm}$) on the stepping motor assembly.

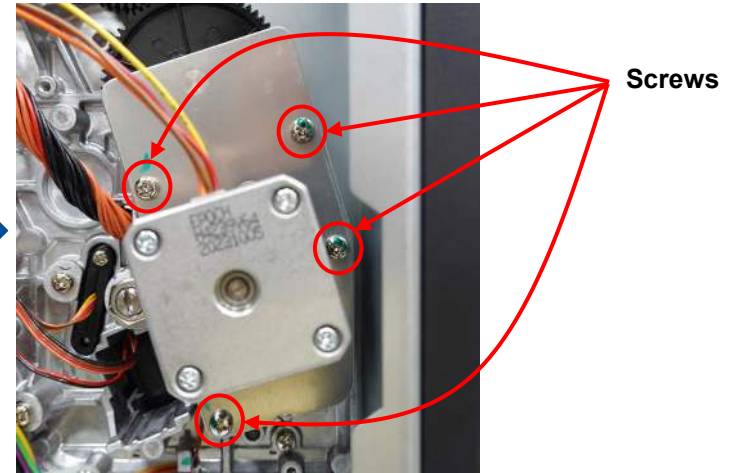
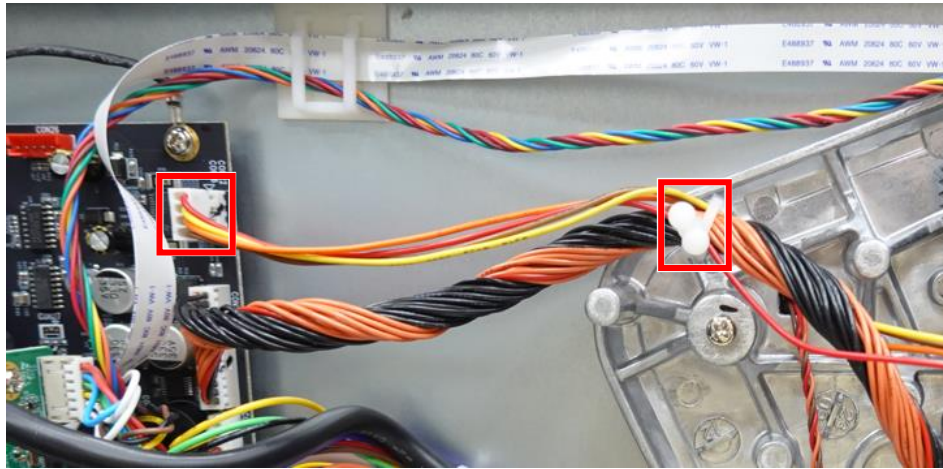

4. Remove/Replace the stepping motor assembly. (including gears and stepping motor)



Stepping motor assembly

5. Reassemble the parts in the reverse procedures.

3.11 Replacing the Gap/Black Mark Sensor Module

1. Follow the steps in [Before You Begin](#) to prepare the printer.
2. Refer to [Removing the Electronics Cover](#) to remove the electronics cover.
3. Disconnect three gap/black mark sensor connectors from the main board. Loosen two cable ties.

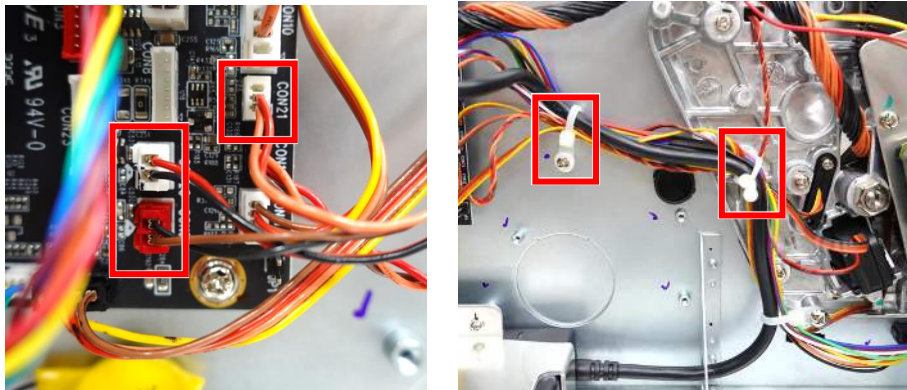

4. Raise the media cover. At the bottom of the gap/black mark sensor module, there is a plastic tab to latch the sensor assembly to the mechanism. Use a piece of paper (thick stiff paper) to make it through the slot and put the paper under the tab. Pull the media sensor assembly out of the mechanism.

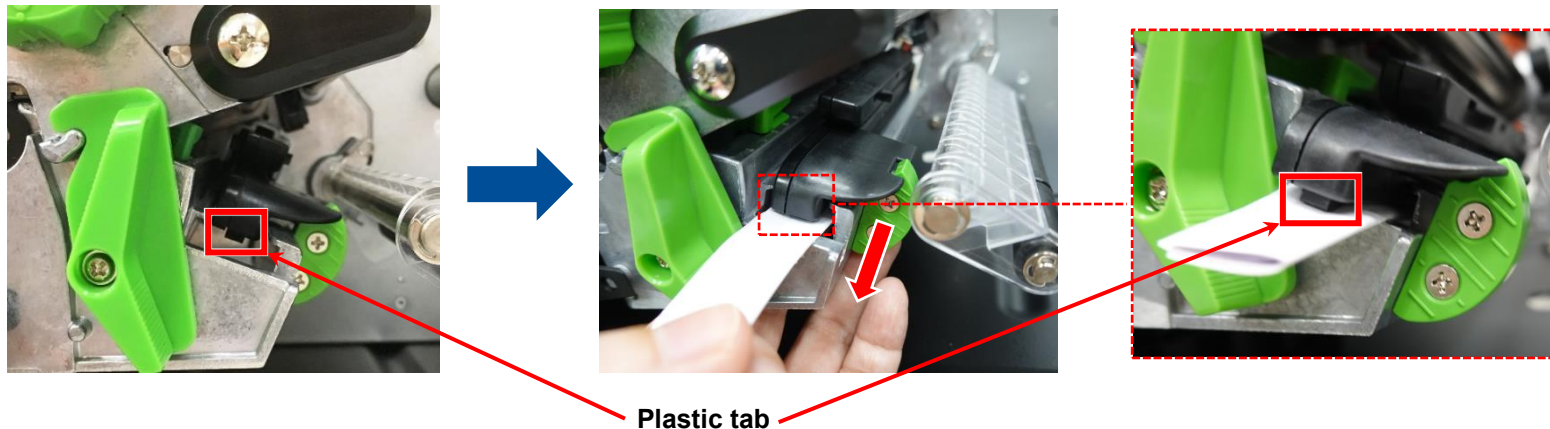

5. Remove/Replace the gap/black mark sensor.

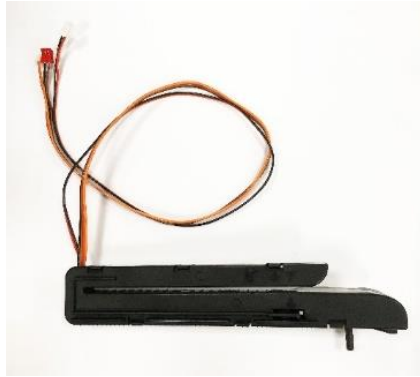

Note:

When installing a new sensor module, please note that there is a spring in the center wall of the printer, please press down it when installing to avoid being hit. Attach the sensor module into the rail.

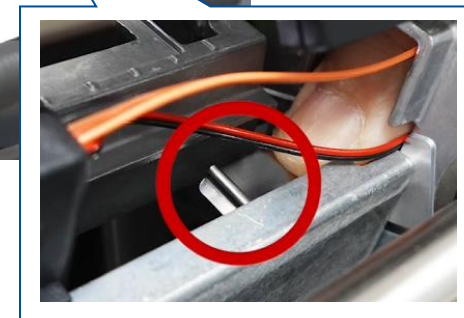
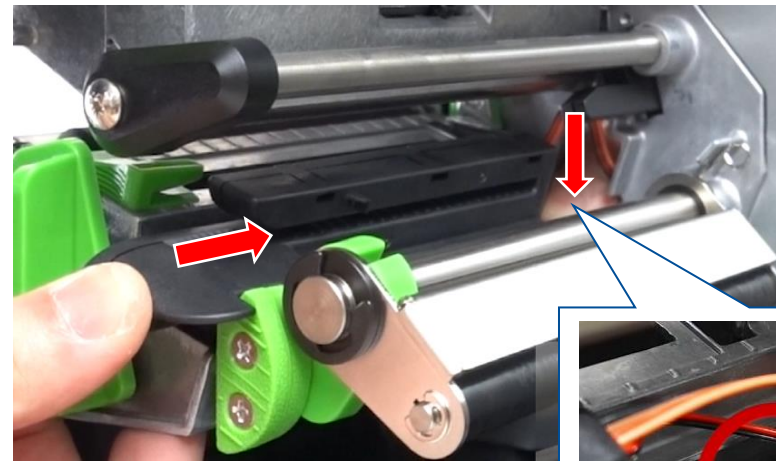
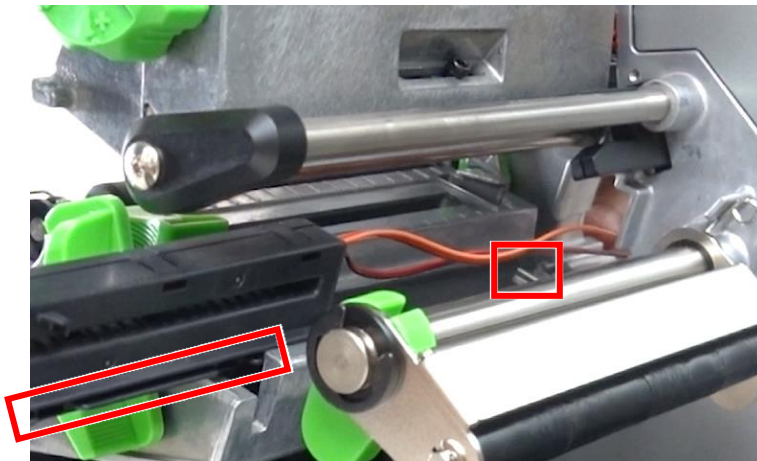

6. Reassemble the parts in the reverse procedures.

3.12 Cutter Module Installation (Option)



1. Follow the steps in [Before You Begin](#) to prepare the printer.
2. Refer to [Removing the Lower Front Panel](#) to remove the lower front panel.

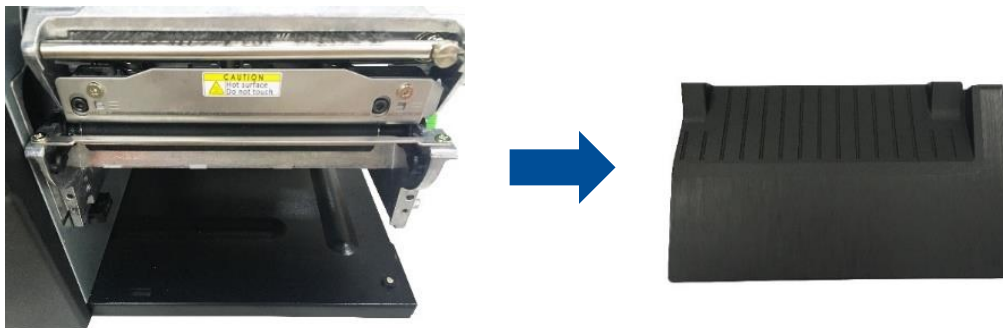

3. Open the cutter module panel. Install cutter module cable on printer cable socket as indicated.
4. Align the cutter module plate on printer mechanism locating holes to fasten two screws (fastened by $7.5 \text{ kg} \pm 15\% \text{ kg-cm}$) as indicated.
5. Close cutter module and fasten one shoulder screw (fastened by $7.5 \text{ kg} \pm 15\% \text{ kg-cm}$) to fix hinge.

Note: Please make sure shoulder screw did not interfere with hinge.

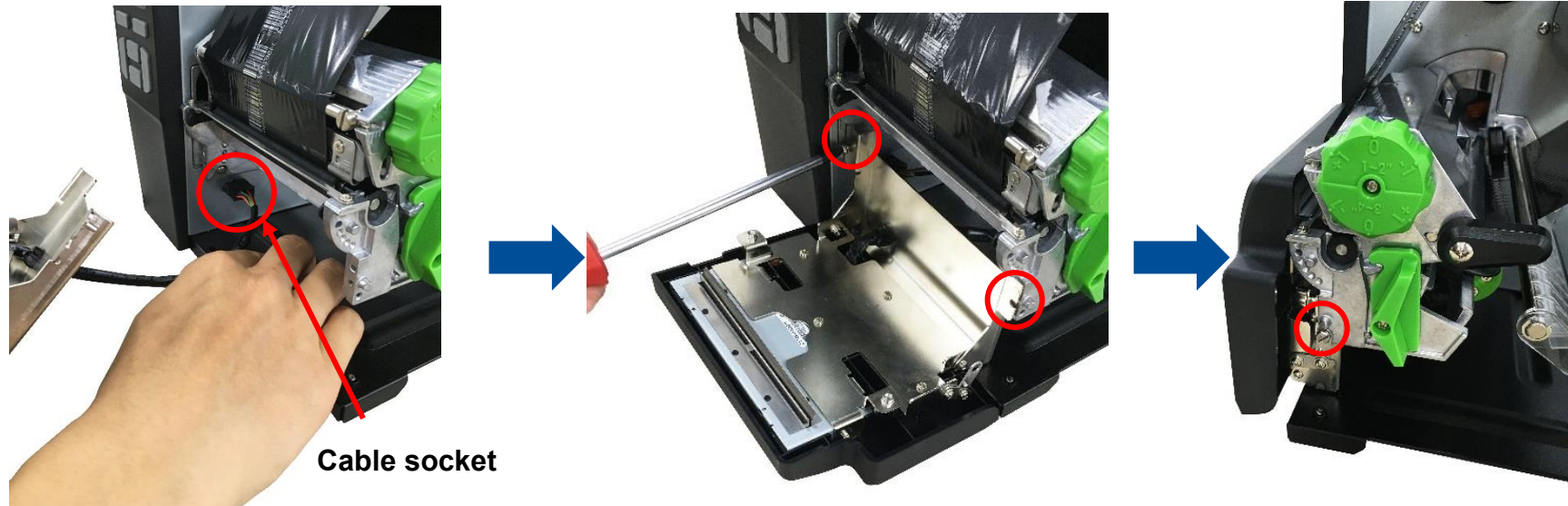

3.13 Peel-off Kit Installation (Option)

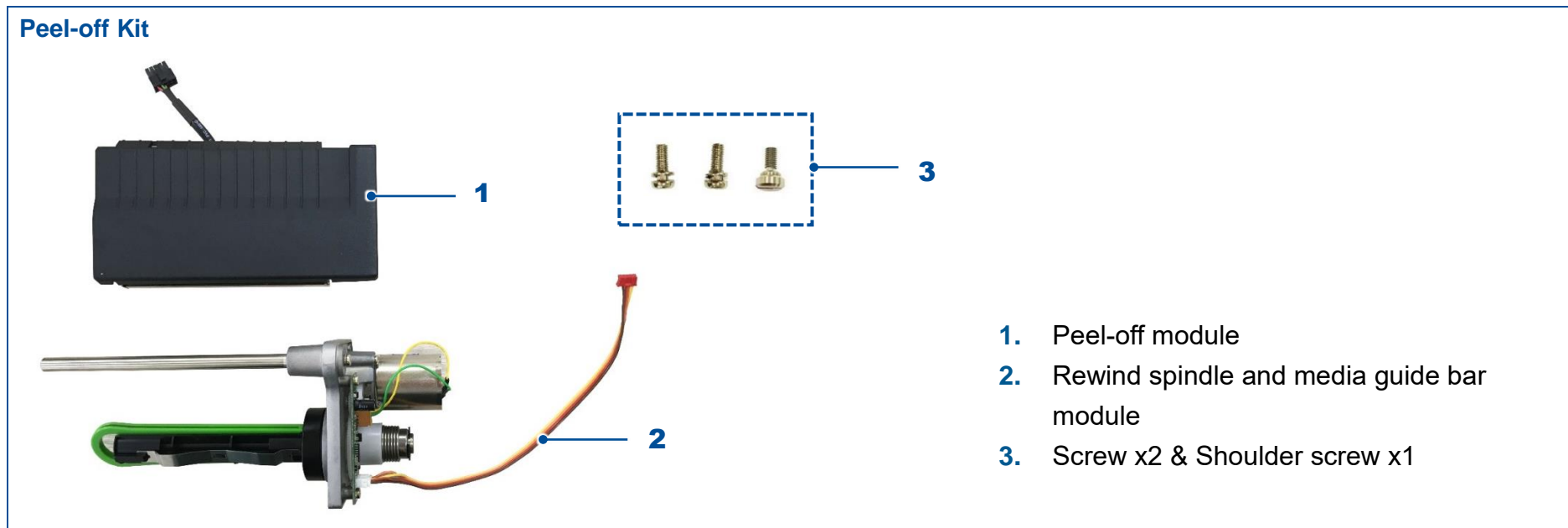

■ Peel-off Sensor Module Installation

1. Follow the steps in [Before You Begin](#) to prepare the printer.
2. Refer to [Removing the Lower Front Panel](#) to remove the lower front panel.

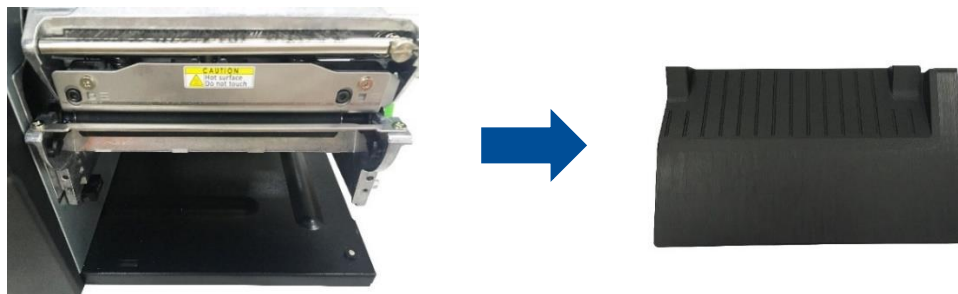

3. Install peel-off sensor module cable on printer connector as indicated.

Note: Please push the cable to bottom side to prevent media stuck when peeling the label.

Open the peel-off sensor module panel and align the module plate on printer mechanism locating holes to fasten two screws (fastened by $7.5 \text{ kg} \pm 15\% \text{ kg-cm}$) and one shoulder screw (fastened by $7.5 \text{ kg} \pm 15\% \text{ kg-cm}$) as indicated.

Note: Please make sure shoulder screw did not interfere with hinge.

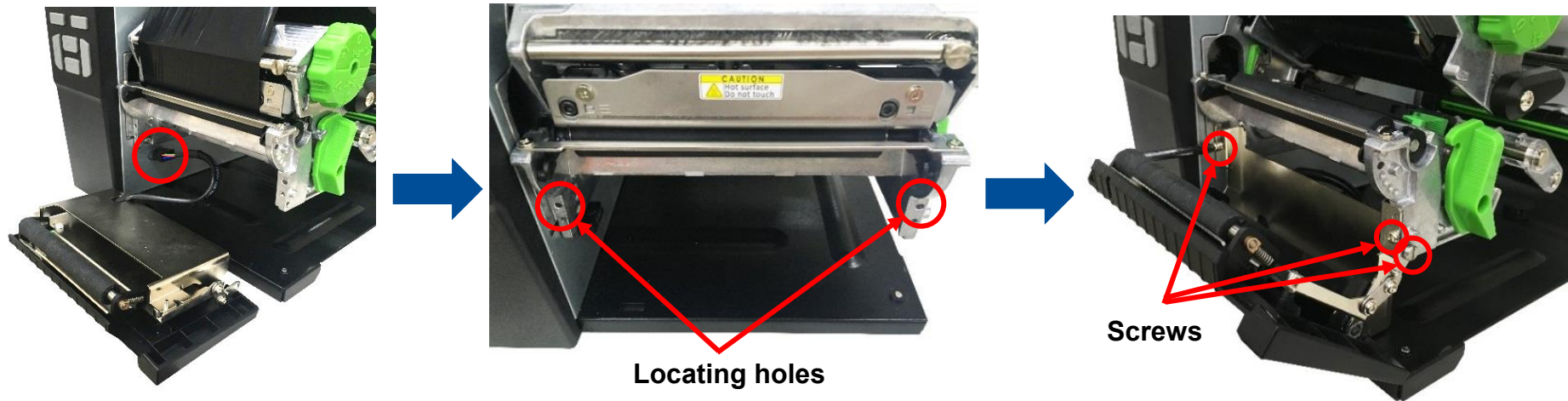

4. Close the peel-off sensor module and complete installation.

■ Rewind Spindle and Media Guide Bar Installation

1. Refer to [Removing the Electronics Cover](#) to remove the electronic cover.
2. Push the reserved cover on the electronic side with a force of 3kg ~ 5kg, then cover will be partially released on the printer middle plate and remove the reserved cover from the center plate of the printer on the media side.

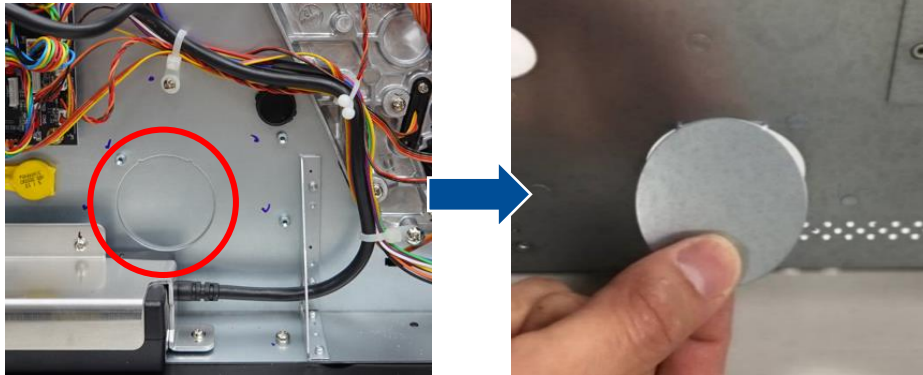

3. Remove the black plastic cover (on the electronic side) by push both sides of cover as indicated.

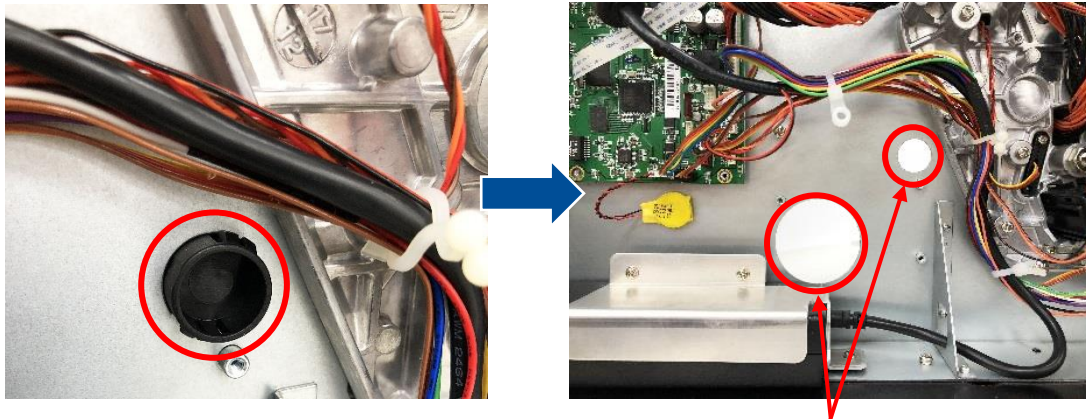

Positioning holes

4. Install the rewind spindle and media guide bar on electronic side.
Fasten three screws (fastened by $7.5 \text{ kg} \pm 15\% \text{ kg-cm}$) on rewind spindle and media guide bar module as indicated.

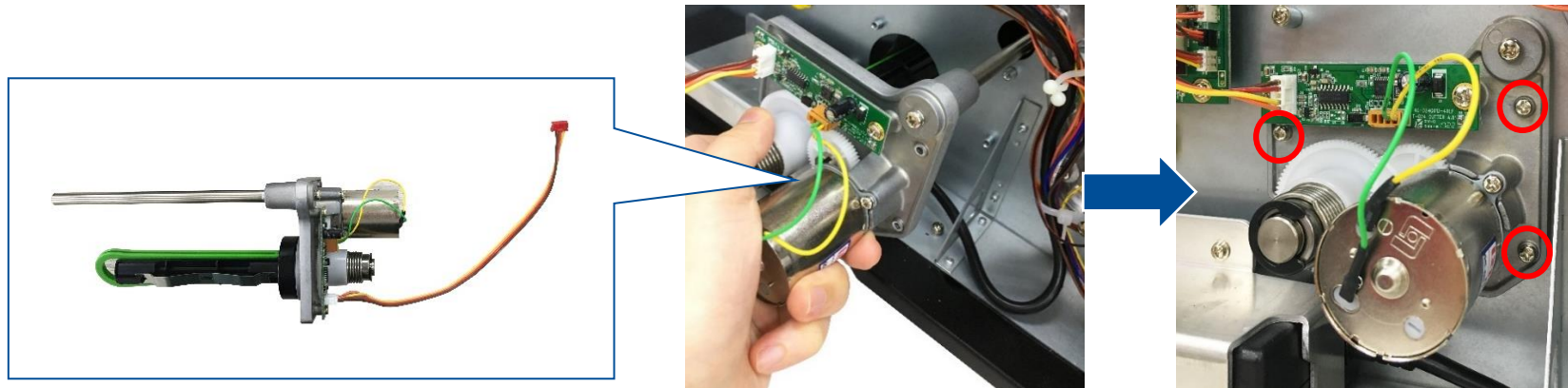

5. Connect the rewinder module cable to the main board socket (CON26/ red).

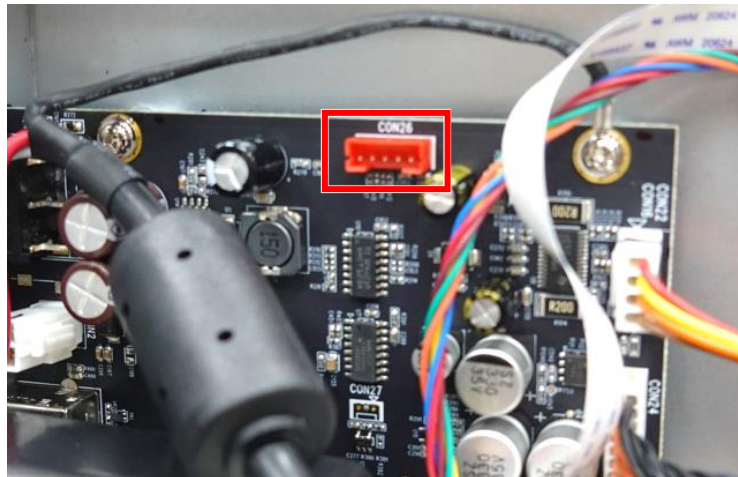

6. Complete the installation of rewind spindle and media guide bar module.
7. Reassemble the parts in the reverse procedures.

3.14 Replacing the Internal Full Rewinder Kit (Option)

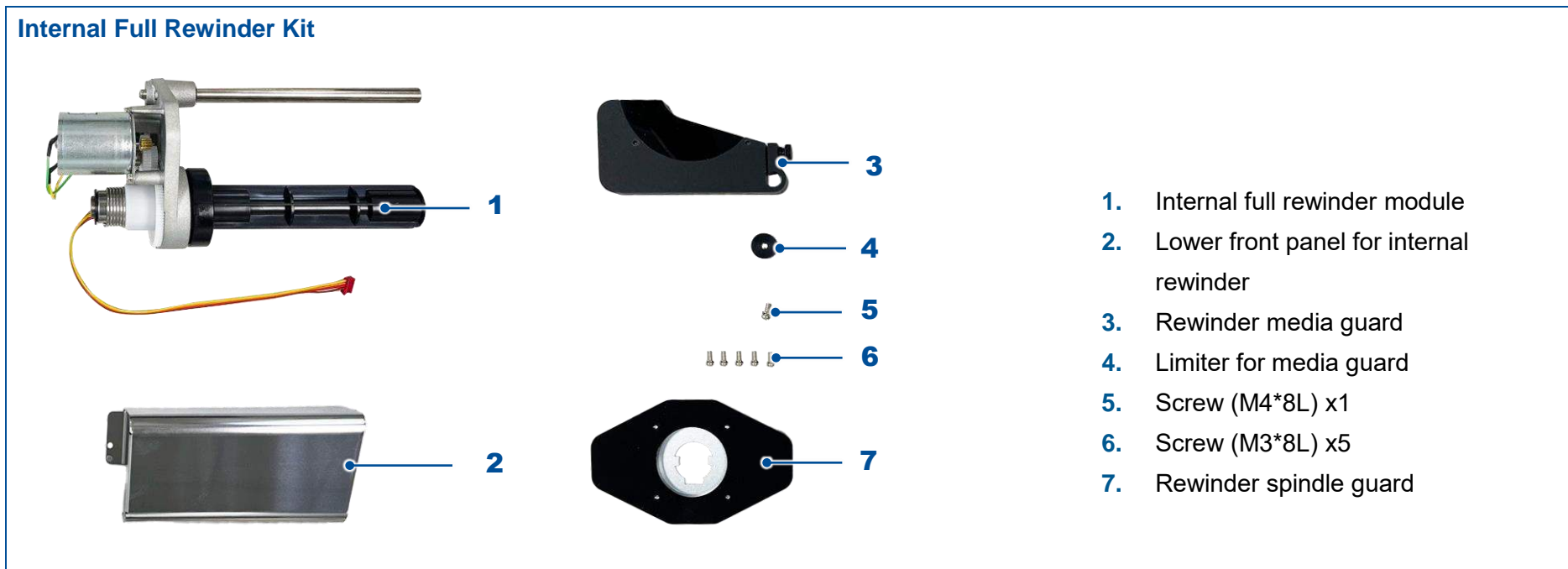

1. Follow the steps in [Before You Begin](#) to prepare the printer.
2. Refer to [Removing the Electronics Cover](#) to remove the electronics cover.
3. Push the reserved cover on the electronic side with a force of 3kg ~ 5kg, then cover will be partially released on the printer middle plate and remove the reserved cover from the center plate of the printer on the media side.

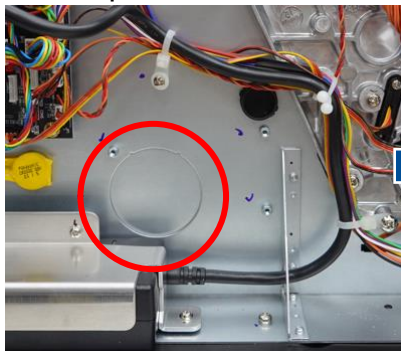

4. Remove the black plastic cover (on the electronic side) by push both sides of cover as indicated.

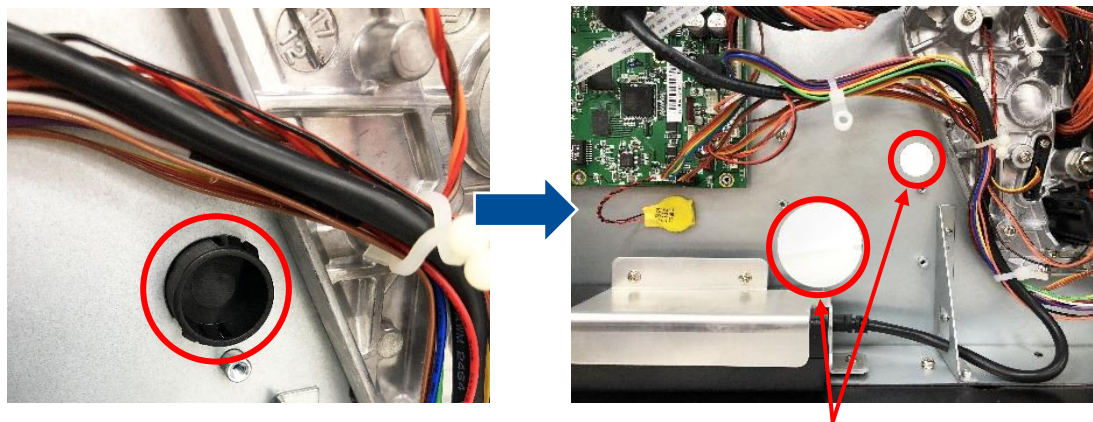

Positioning holes

5. Install the internal full rewriter module on the positioning holes and fix the module by fasten three screws (M3*8L/ fastened by 10.5 kg±15% kg-cm) as indicated.

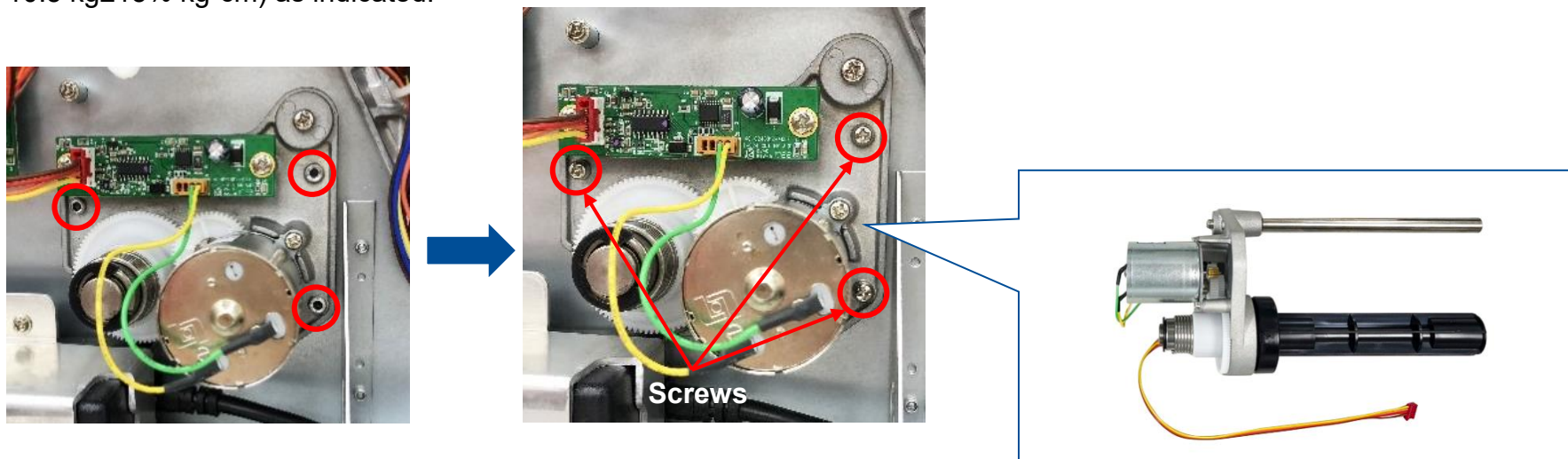

Screws

8. Connect the full rewriter module cable to the main board socket (CON26/ red) as indicated.

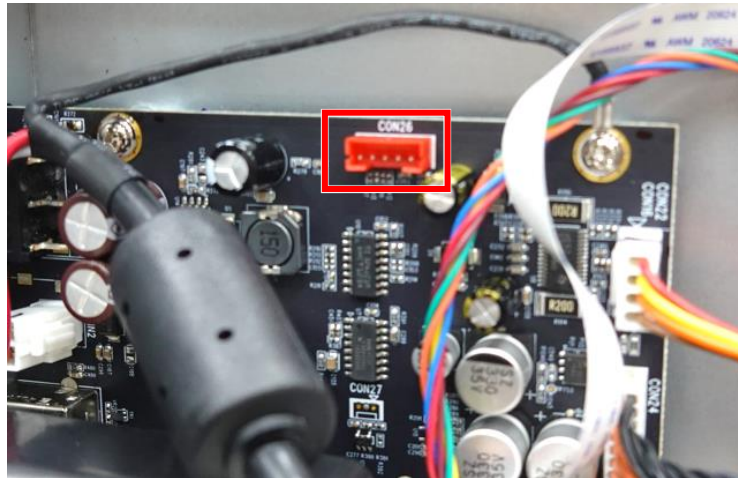

6. Reassemble the electronics cover.
7. Raise the media cover to install the rewriter spindle guard.
Attach the rewriter media guard to the guide bar first, then attach the limiter and secure it with a screw (M4*8L).

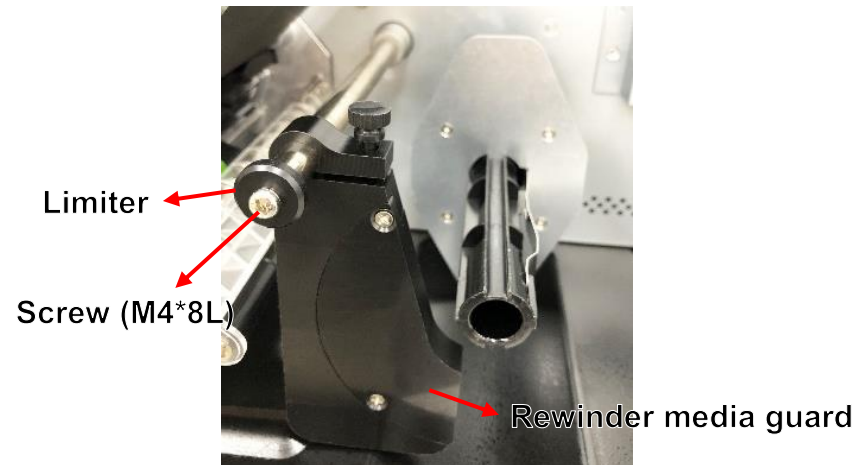

8. Refer to [Removing the Lower Front Panel](#) to remove the lower front panel.

9. Install and fix the lower front panel for internal rewinder by fasten two screws (M3*8L/ fastened by $7.5 \text{ kg} \pm 15\% \text{ kg-cm}$) as indicated.
Complete the installation of internal full rewinder kit.

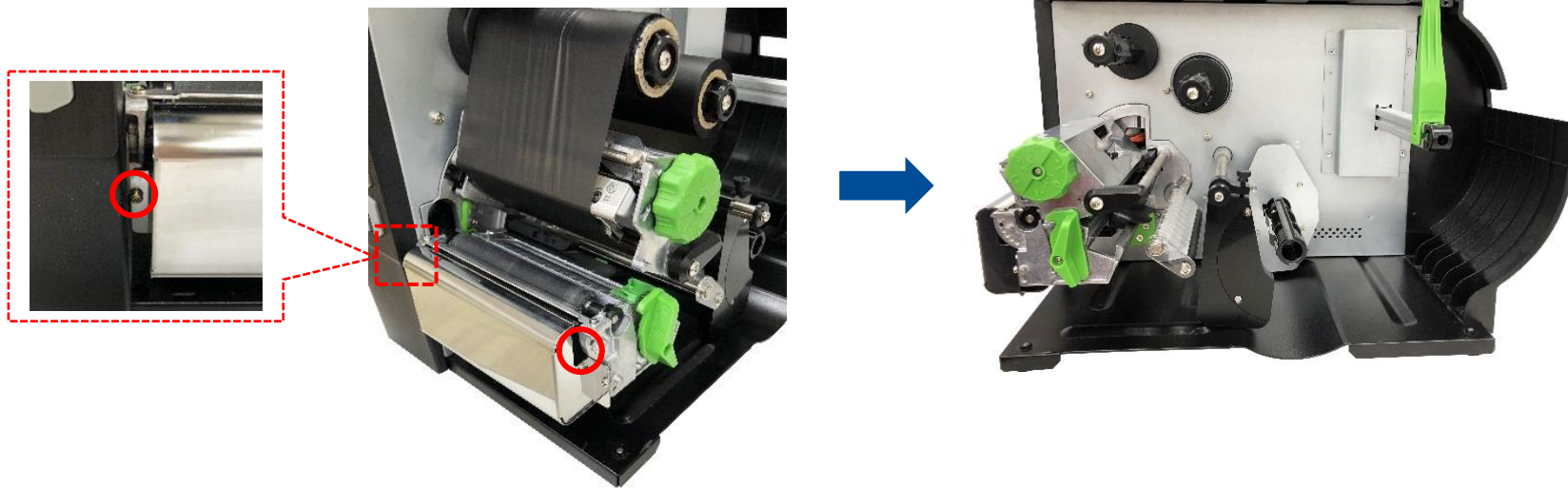

3.15 Slot-in Wireless Housing Installation (Option)

1. Follow the steps in [Before You Begin](#) to prepare the printer.
2. Refer to [Removing the Electronics Cover](#) to remove the electronic cover.
3. Connect the slot-in wireless transfer module housing board cables to the main board (CON28 & CON13) first. Take off the reserved plate by removing two screws (fastened by $5.5 \text{ kg} \pm 15\% \text{ kg-cm}$) on rear of printer.

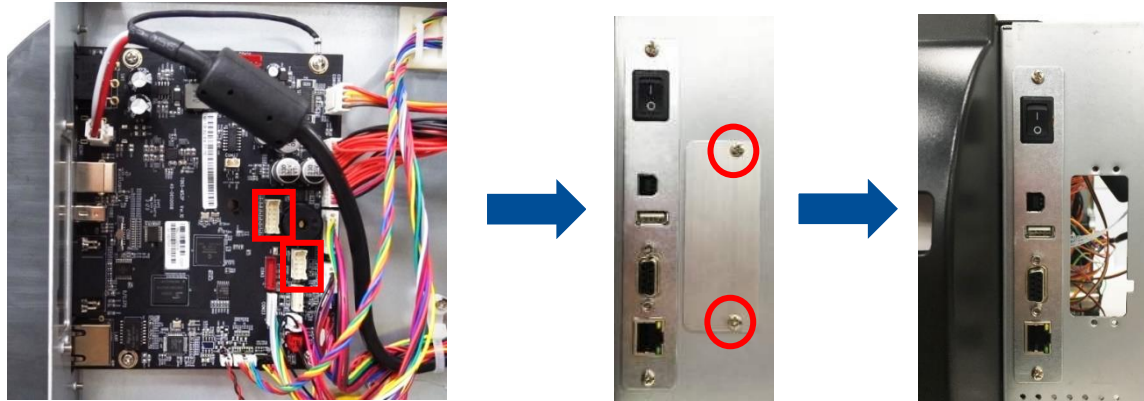

4. Install the slot-in wireless housing on the rear of the printer and fix the two screws. ($5.5 \text{ kg} \pm 15\% \text{ kg-cm}$) Connect another side of the cables to the slot-in wireless transfer module housing board. Reassemble the parts in the reverse procedures.



3.16 GPIO Interface Assembly Installation (Option)

GPIO Interface Assembly

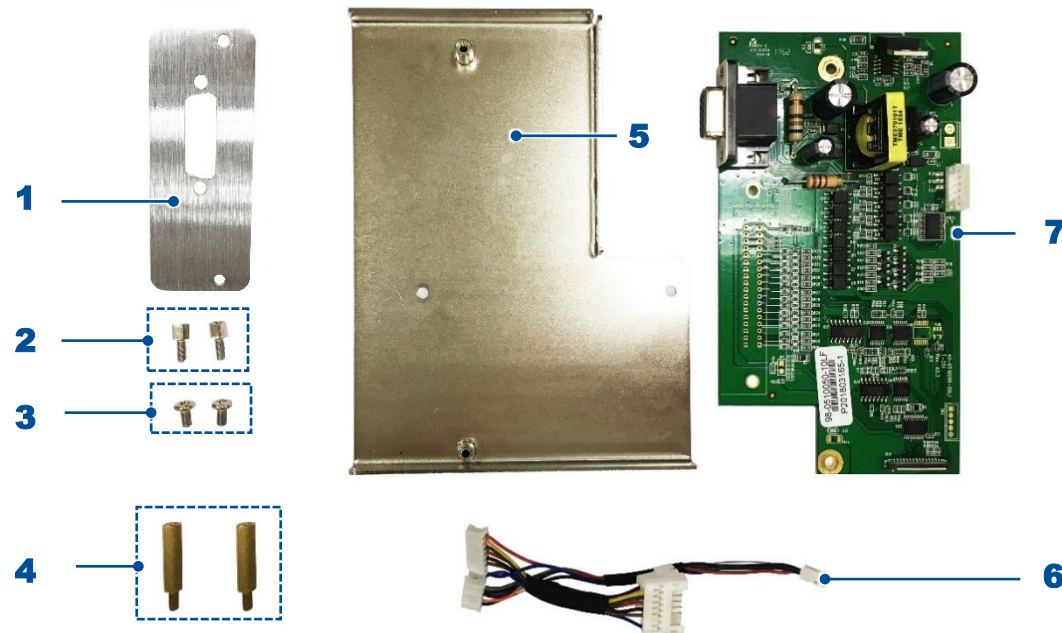

1. GPIO interface board
2. Hexagon screw x2
3. Screw x2
4. Copper pillar x2
5. GPIO mounting plate
6. GPIO transfer cable
7. GPIO board

1. Follow the steps in [Before You Begin](#) to prepare the printer.
2. Refer to [Removing the Electronics Cover](#) to remove the electronic cover.
3. Take off the reserved plate by removing two screws (fastened by 5.5 kg±15% kg-cm) on rear of printer.
Replace the two screws on the bottom of the main board with copper pillars. (fastened by 7.5 kg±15% kg-cm)

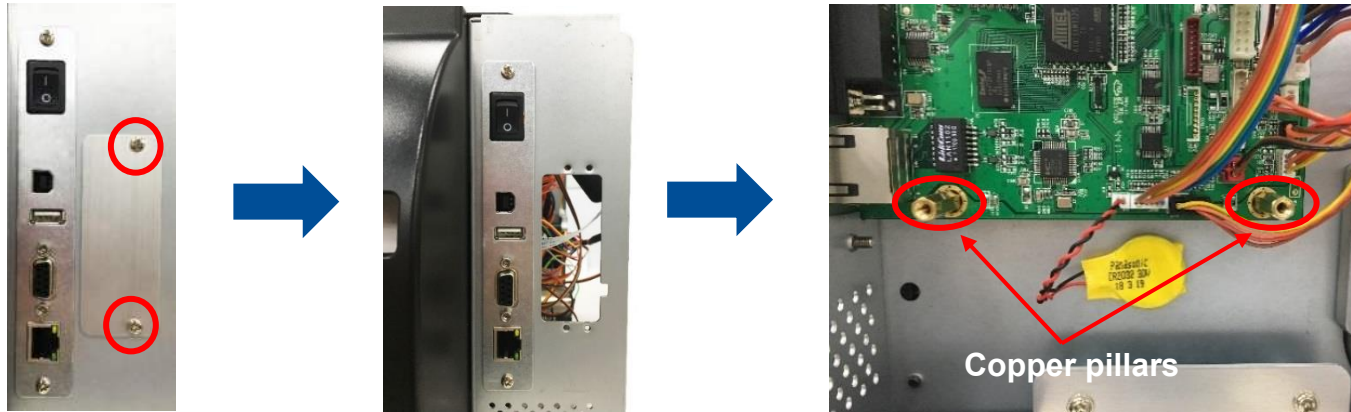

Note: Refer to [Slot-in Wireless Housing Installation \(Option\)](#) to remove the housing. (if module installed)

4. Remove the two cable connectors (CON6 and CON10) from the main board and insert the GPIO transfer cables (#1), then connect the two removed cables to the GPIO transfer connectors (#2) as indicated.

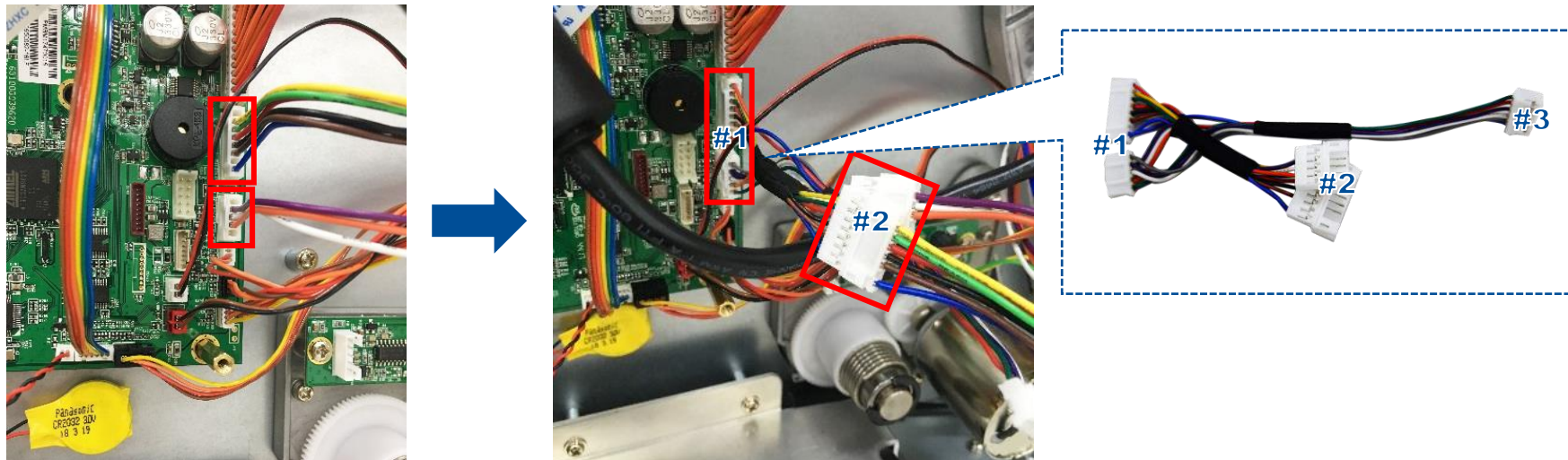

5. Fasten the two screws (fastened by $5.5 \text{ kg} \pm 15\% \text{ kg-cm}$) on the GPIO mounting plate first. Then, aligning the GPIO board to the two locating holes on GPIO mounting plate and fasten another two screws (fastened by $5.5 \text{ kg} \pm 15\% \text{ kg-cm}$) to secure the GPIO board. Insert the rest connector of GPIO transfer cable (#3) to GPIO board. Fasten the two screws and the two hexagon screws on the GPIO interface board on the rear of printer.

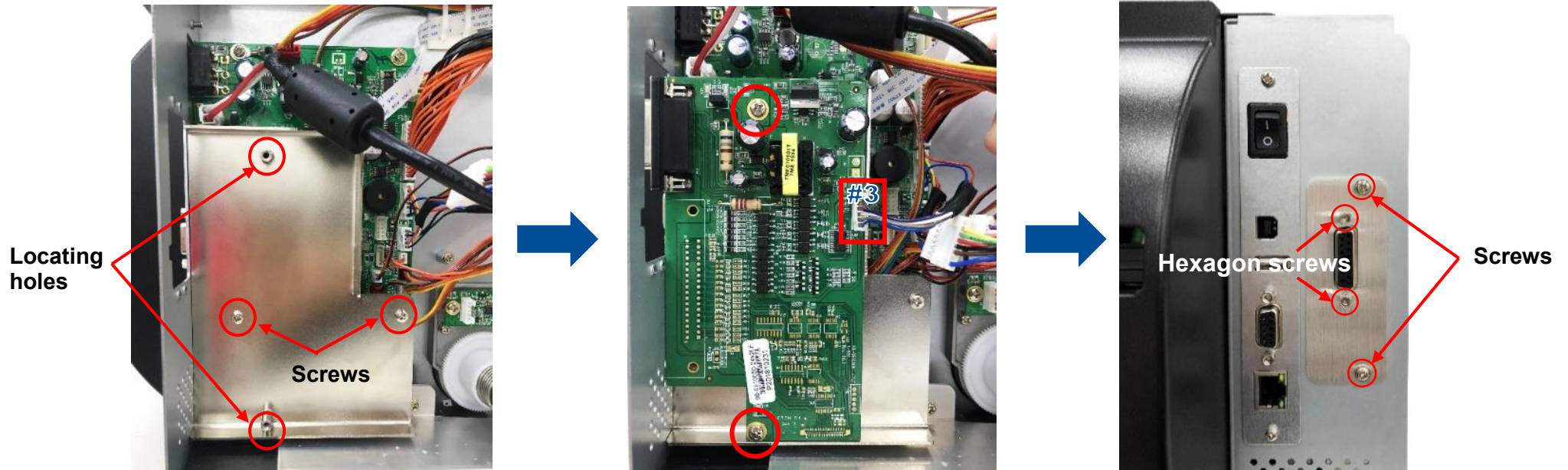

6. Reassemble the parts in the reverse procedures.

3.17 Bluetooth Module Installation (Option)

1. Follow the steps in [Before You Begin](#) to prepare the printer.
2. Refer to [Removing the Electronics Cover](#) to remove the electronic cover.
3. Remove the screw (fastened by $5\text{ kg}\pm 15\%$ kg-cm) on the panel assembly as indicated.

Referring to [Replacing the Control Panel Assembly](#), open the panel assembly and install the Bluetooth module by securing the two screws (fastened by $3.5\text{ kg}\pm 15\%$ kg-cm) as indicated. Then, install the panel assembly back.

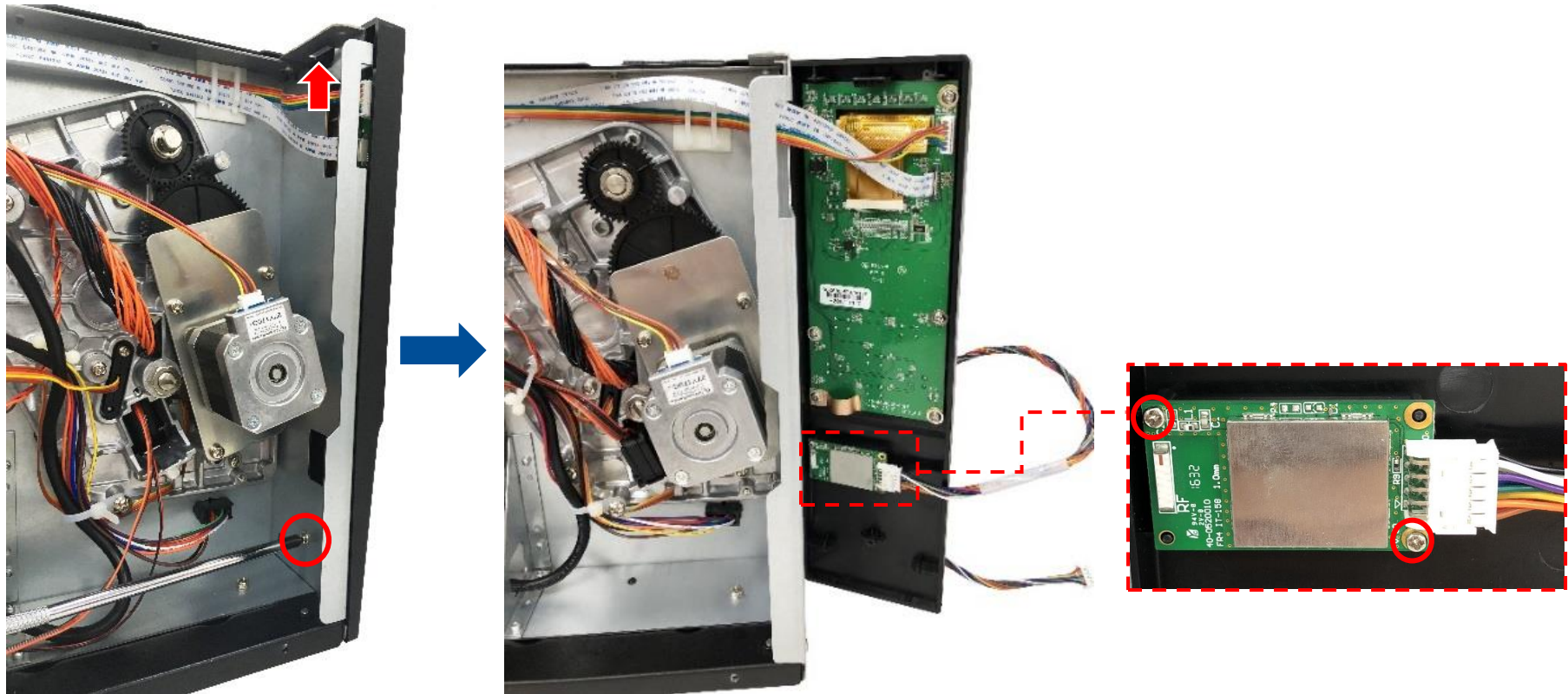

4. Connect the Bluetooth module cable on the main board (CON13) as indicated.

Note: Refer to Slot-in Wireless Housing Installation (Option) to remove the housing. (if module installed)

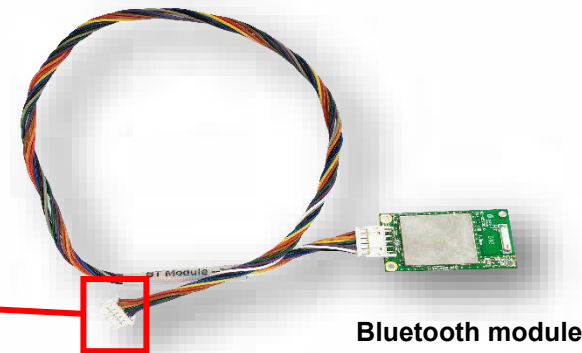
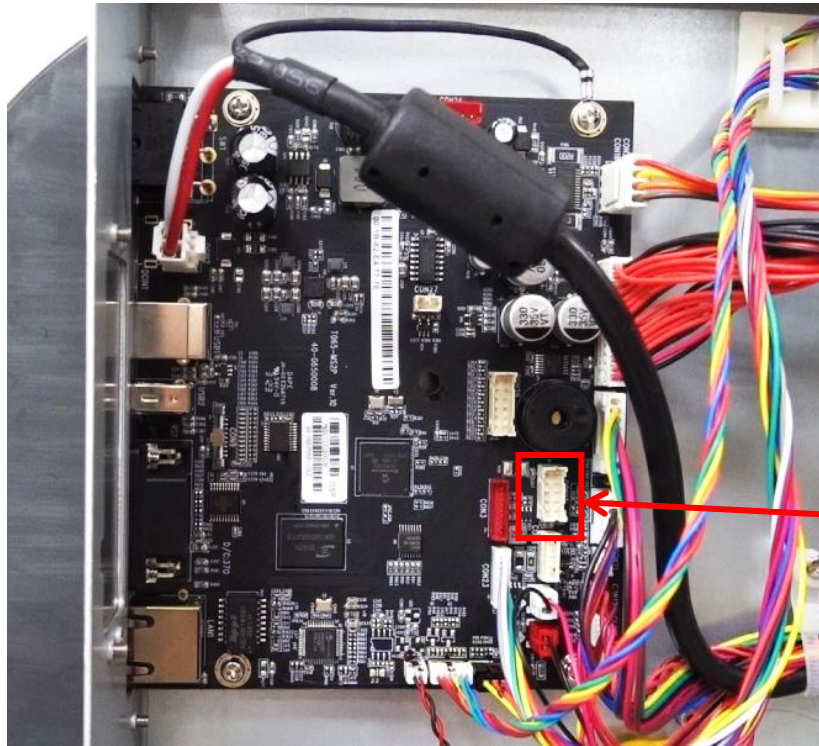

5. Reassemble the parts in the reverse procedures.

3.18 Linerless Kit Installation (Option)

Tear / Cutter linerless kit

1. Linerless tear / Linerless cutter

2. Linerless damper

3. Linerless pads*2

4. Rubber handle

5. Self-tapping screw*2 (TP3*9)

6. Turning screws*2 (M3*4L)

7. Machine screws*1 (M3*6L)

8. Rubber cover

9. Linerless pad

10. Linerless roller

11. Cutter tray (Linerless cutter kit only)

1. Follow the steps in [Before You Begin](#) to prepare the printer.
2. Move the tab outward then pull the panel inward to remove the lower front panel.



3. Refer to [Replacing the Platen Roller Assembly](#) to remove the platen roller (black) and remove the tear bar by removing the two screws.

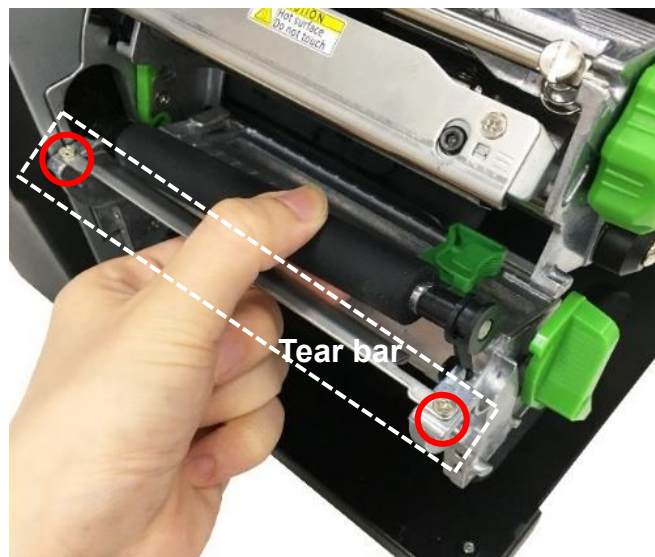

4. Fasten the two turning screws (M3*4L; provided in the kit/ fastened by 7.5 kg±15% kg-cm) on printer mechanism as indicated.

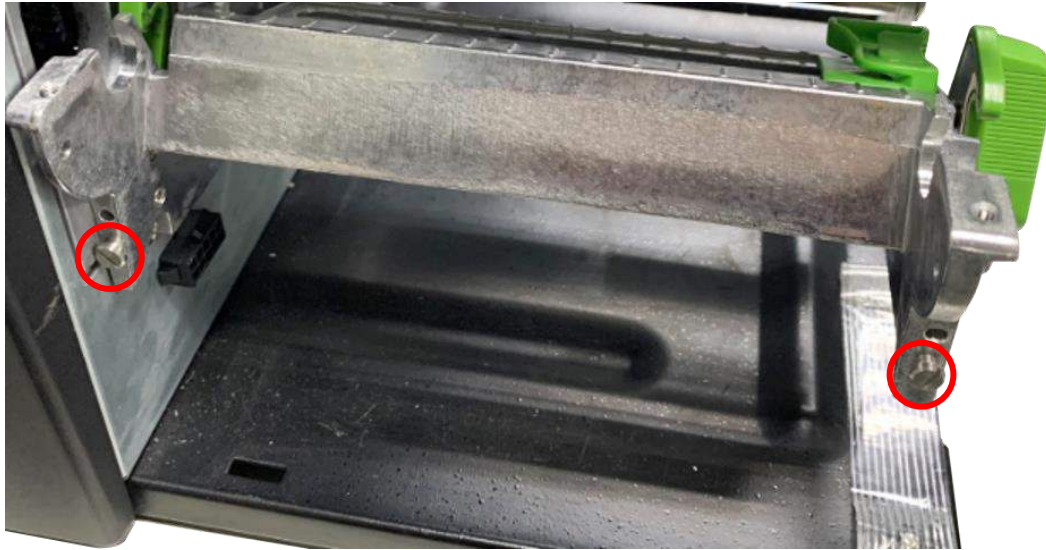

5. Move the label guide (green) to the outermost side to install the rubber cover and stick the linerless pad on the lower base.

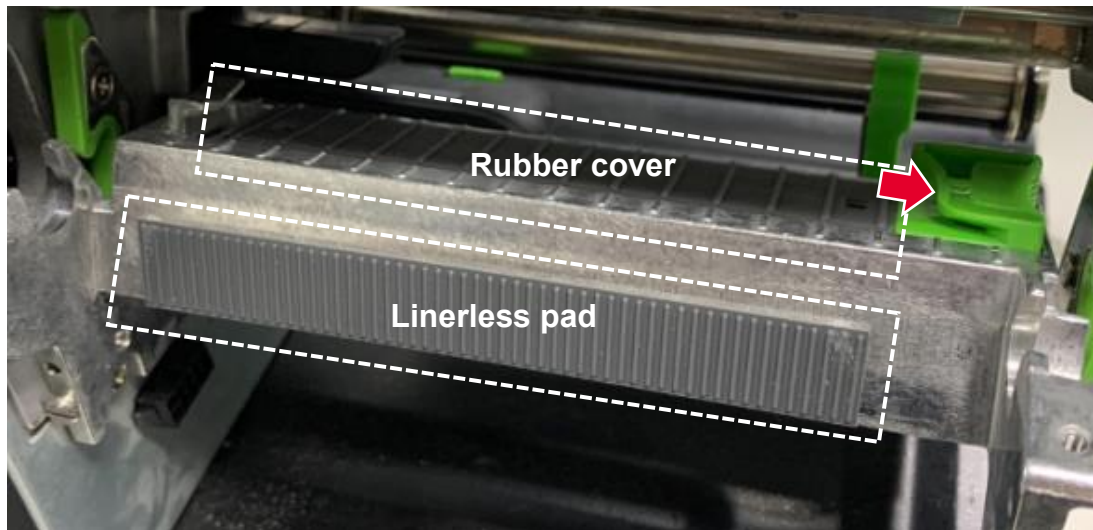

6. Install the linerless roller.



7. Remove the two screws and replace the cover (green) from plastic to rubber.

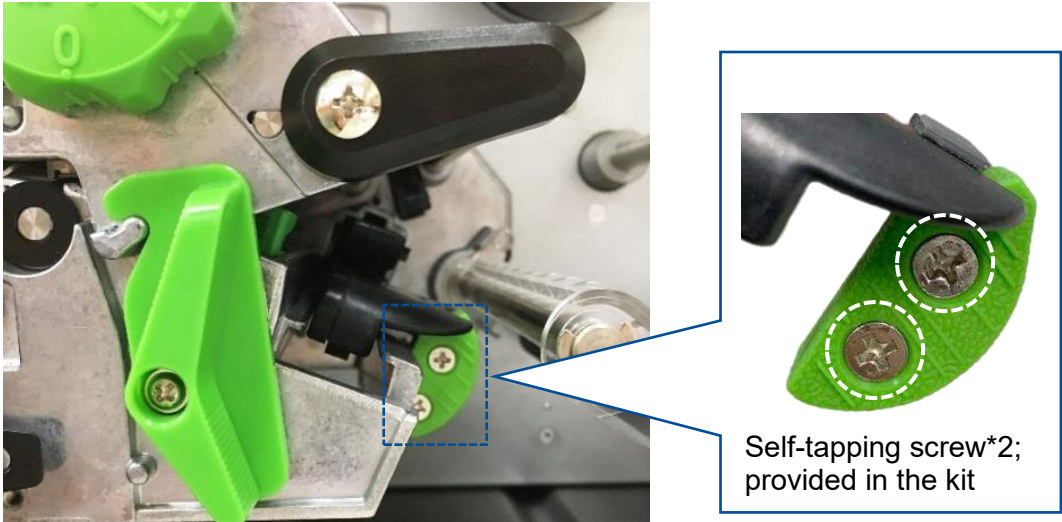

8. Stick the two linerless pads on the sensor module as indicated.

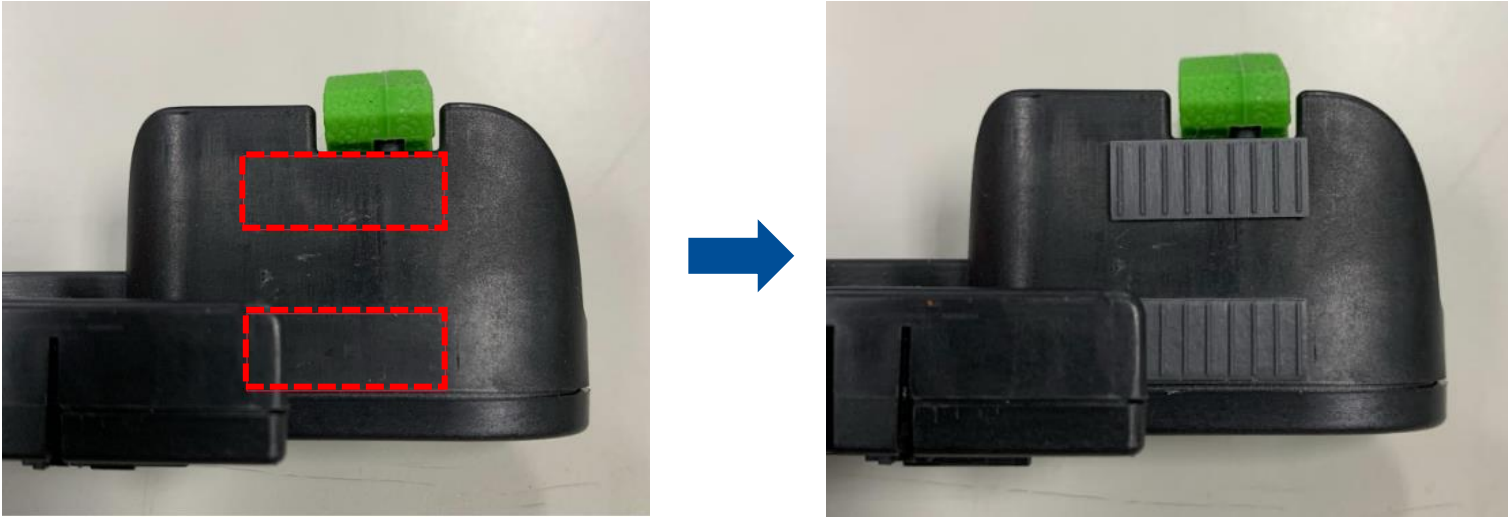

9. Refer to [Removing the Electronics Cover](#) to remove the electronic cover. Remove the one screw to replace the linerless damper.

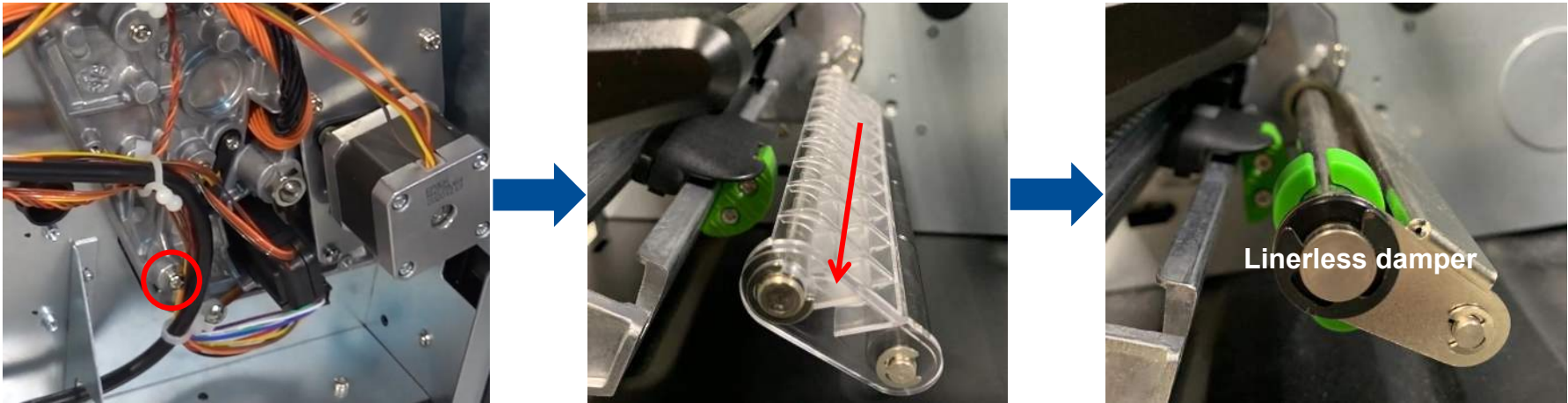

10. Plug the tear (or cutter) module mini DIN cable connector into the printer receptacle.

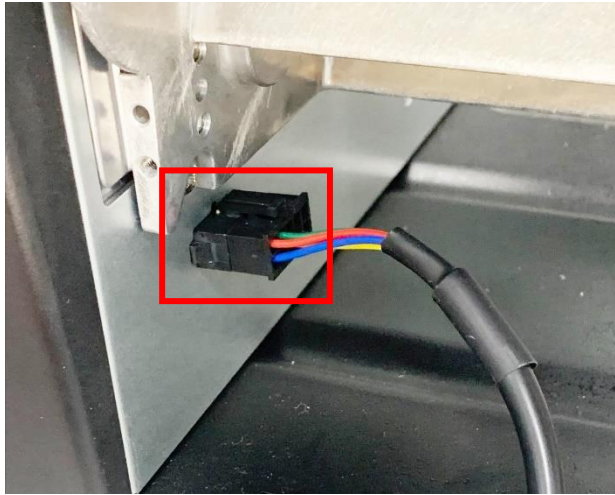

11. Place the tear (or cutter) module in position and use the machine screw (M3*6L/ fastened by 7.5 kg±15% kg-cm) provided in the kit to install the tear (or cutter) module on the lower support assembly.



12. For the linerless cutter module, the cutter tray is mounted on the cutter panel as required.



4. Troubleshooting

4.1 Common Issues

Problem	Possible Cause	Recovery Procedure
Power indicator does not illuminate	<ul style="list-style-type: none"> ■ The power cord is not properly connected. ■ The power switch is closed. 	<ul style="list-style-type: none"> ■ Plug the power cord in printer and outlet. ■ Switch the printer on.
Carriage Open	<ul style="list-style-type: none"> ■ The printer carriage is open. 	<ul style="list-style-type: none"> ■ Close the print carriage.
Not Printing	<ul style="list-style-type: none"> ■ Check if interface cable is well connected. ■ Check if wireless or Bluetooth device is well connected. ■ The port in the Windows driver is not correct. 	<ul style="list-style-type: none"> ■ Re-connect cable to interface or change a new cable. ■ Reset the wireless device setting. ■ Select the correct printer port in the driver. ■ Clean the printhead. ■ Printhead's harness connector is not well connected with printhead. Turn off the printer and plug the connector again. ■ Check your program if there is a command - PRINT at the end of the file and there must have CRLF at the end of each command line.
No print on the label	<ul style="list-style-type: none"> ■ Label or ribbon is loaded not correctly. ■ Use wrong type paper or ribbon 	<ul style="list-style-type: none"> ■ Follow the instructions in loading the media and ribbon. ■ Ribbon and media are not compatible. ■ Verify the ribbon-inked side. ■ The print density setting is incorrect.
No Ribbon	<ul style="list-style-type: none"> ■ Running out of ribbon. ■ The ribbon is installed incorrectly. 	<ul style="list-style-type: none"> ■ Supply a new ribbon roll. ■ Refer to user's manual to reinstall the ribbon.
No Paper	<ul style="list-style-type: none"> ■ Running out of label. ■ The label is installed incorrectly. ■ Gap/black mark sensor is not calibrated. 	<ul style="list-style-type: none"> ■ Supply a new label roll. ■ Refer to user's manual to reinstall the label roll. ■ Calibrate the gap/black mark sensor.

Problem	Possible Cause	Recovery Procedure
Paper Jam	<ul style="list-style-type: none"> ■ Gap/black mark sensor is not set properly. ■ Make sure label size is set properly. ■ Labels may be stuck inside the printer mechanism. 	<ul style="list-style-type: none"> ■ Calibrate the media sensor. ■ Set media size correctly. ■ Remove the stuck label inside the printer mechanism.
Take Label	<ul style="list-style-type: none"> ■ Peel function is enabled. 	<ul style="list-style-type: none"> ■ If peeler module is installed, please remove the label. ■ If there is no peeler module in front of the printer, please switch off the printer and install it. ■ Check if the connector is plugging correctly.
Can't downloading the file to memory (FLASH / DRAM/CARD)	<ul style="list-style-type: none"> ■ The space of memory is full. 	<ul style="list-style-type: none"> ■ Delete unused files in the memory.
Poor Print Quality	<ul style="list-style-type: none"> ■ Ribbon and media is loaded incorrectly. ■ Dust or adhesive accumulation on the print head. ■ Print density is not set properly. ■ Printhead element is damaged. ■ Ribbon and media are incompatible. ■ The printhead pressure is not set properly. 	<ul style="list-style-type: none"> ■ Reload the supply. ■ Clean the print head. ■ Clean the platen roller. ■ Adjust the print density and print speed. ■ Run printer self-test and check the print head test pattern if there is dot missing in the pattern. ■ Change proper ribbon or proper label media. ■ Adjust the printhead pressure adjustment knob. ■ The release lever does not latch the printhead properly.
Missing printing on the left or right side of label	<ul style="list-style-type: none"> ■ Wrong label size setup. 	<ul style="list-style-type: none"> ■ Set the correct label size.
Gray line on the blank label	<ul style="list-style-type: none"> ■ The print head is dirty. ■ The platen roller is dirty. 	<ul style="list-style-type: none"> ■ Clean the print head. ■ Clean the platen roller.
Irregular printing	<ul style="list-style-type: none"> ■ The printer is in Hex Dump mode. ■ The RS-232 setting is incorrect. 	<ul style="list-style-type: none"> ■ Turn off and on the printer to skip the dump mode. ■ Re-set the RS-232 setting.
Label feeding is not stable (skew) when printing	<ul style="list-style-type: none"> ■ The media guide does not touch the edge of the media. 	<ul style="list-style-type: none"> ■ If the label is moving to the right side, please move the

Problem	Possible Cause	Recovery Procedure
		<p>label guide to left.</p> <ul style="list-style-type: none"> ■ If the label is moving to the left side, please move the label guide to right.
Skip labels when printing	<ul style="list-style-type: none"> ■ Label size is not specified properly. ■ Sensor sensitivity is not set properly. ■ The media sensor is covered with dust. 	<ul style="list-style-type: none"> ■ Check if label size is setup correctly. ■ Calibrate the sensor by Auto Gap or Manual Gap options. ■ Clear the GAP/Black mark sensor by blower.
Wrinkle Problem	<ul style="list-style-type: none"> ■ Printhead pressure is incorrect. ■ Ribbon installation is incorrect. ■ Media installation is incorrect. ■ Print density is incorrect. ■ Media feeding is incorrect. 	<ul style="list-style-type: none"> ■ Please refer to the chapter 4. ■ Please set the suitable density to have good print quality. ■ Make sure the label guide touch the edge of the media guide.
RTC time is incorrect when reboot the printer	<ul style="list-style-type: none"> ■ The battery has run down. 	<ul style="list-style-type: none"> ■ Check if there is a battery on the main board.
The left side printout position is incorrect	<ul style="list-style-type: none"> ■ Wrong label size setup. ■ The parameter Shift X in LCD menu is incorrect. 	<ul style="list-style-type: none"> ■ Set the correct label size. ■ Press [Menu] → [Setting] → [Shift X] to fine tune the parameter of Shift X.
The printing position of small label is incorrect	<ul style="list-style-type: none"> ■ Media sensor sensitivity is not set properly. ■ Label size is incorrect. ■ The parameter Shift Y in the LCD menu is incorrect. ■ The vertical offset setting in the driver is incorrect. 	<ul style="list-style-type: none"> ■ Calibrate the sensor sensitivity again. ■ Set the correct label size and gap size. ■ Press [Menu] → [Setting] → [Shift Y] → to fine tune the parameter of Shift Y. ■ Set the vertical offset in the driver if you're using BarTender.
LCD panel is dark and keys are not working	<ul style="list-style-type: none"> ■ The cable between main PCB and LCD panel is loose. 	<ul style="list-style-type: none"> ■ Check if the cable between main PCB and LCD is secured or not.
LCD panel is dark but the LEDs are light	<ul style="list-style-type: none"> ■ The printer initialization is unsuccessful. 	<ul style="list-style-type: none"> ■ Turn OFF and ON the printer again. ■ Initialize the printer.
Ribbon encoder sensor doesn't work	<ul style="list-style-type: none"> ■ The ribbon encoder sensor connector is loose. 	<ul style="list-style-type: none"> ■ Fasten the connector.

Problem	Possible Cause	Recovery Procedure
Ribbon end sensor doesn't work	<ul style="list-style-type: none"> ■ The connector is loose. ■ The ribbon sensor hole is covered with dust. 	<ul style="list-style-type: none"> ■ Check the connector. ■ Clear the dust in the sensor hole by the blower.
Cutter is not working	<ul style="list-style-type: none"> ■ The connector is loose. 	<ul style="list-style-type: none"> ■ Plug in the connect cable correctly.

4.2 Knob Adjustment

■ Print head Pressure Adjustment Knob

Print head Pressure Adjustment Knob has 6 levels' adjustment for 1~2" and 3~4" width media.

Different number means different pressure to the media. Due to printer's paper alignment is on left side of the mechanism, different media width requires the different pressure. Users can try which level can meet their expectation.

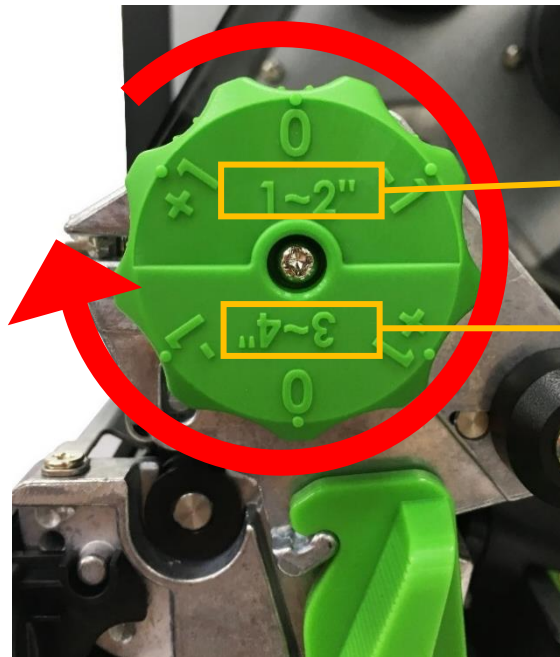

Print Head Pressure Adjustment range from 1~2" media width

Print Head Pressure Adjustment range from 3~4" media width

- **0** means regular media thickness (0.14-0.16mm) pressure setting.
- **-1** means lower pressure for thin paper media
- **+1** means higher pressure for thick media

■ Ribbon Tension Adjustment Knob

Ribbon Tension Adjustment Knob has 5 positions for adjustment. Due to the ribbon is aligned to the inbound of print mechanism, different width of ribbon may need to adjust the tension adjustment knob to avoid the ribbon wrinkle and get the best print quality. Refer to [Mechanism Fine Adjustment to Avoid Ribbon Wrinkles](#) section for how to adjust.

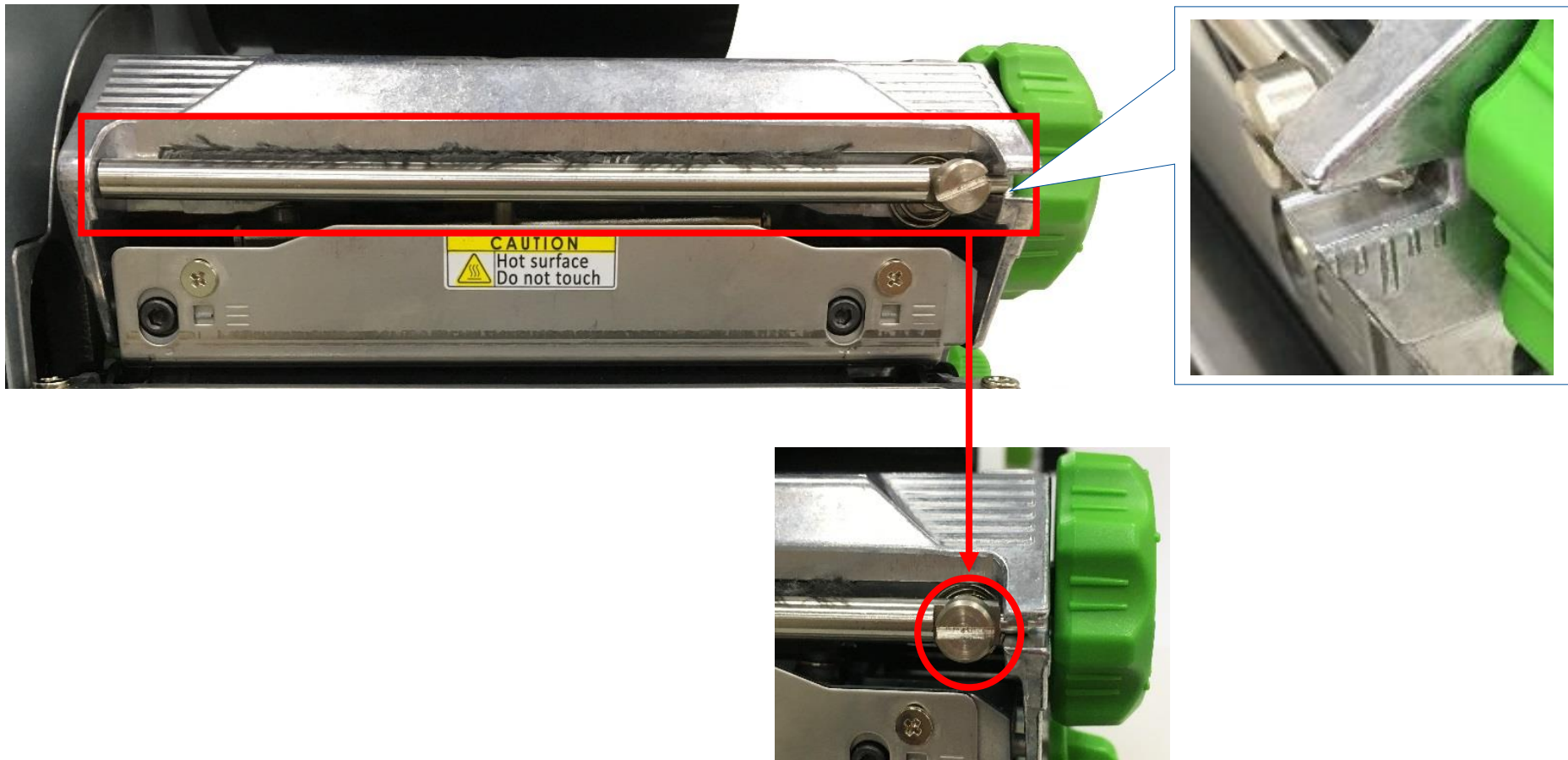

■ Mechanism Fine Adjustment to Avoid Ribbon Wrinkles

Ribbon wrinkle is related to the media width, thickness, print head pressure balance, ribbon film characteristics, print darkness setting...etc. In case the ribbon wrinkle happens, please follow the instructions below to adjust the printer parts.

Ribbon Tension Adjustment Knob has 5 indexes for adjustment. Use flat screw driver to change the ribbon tension.

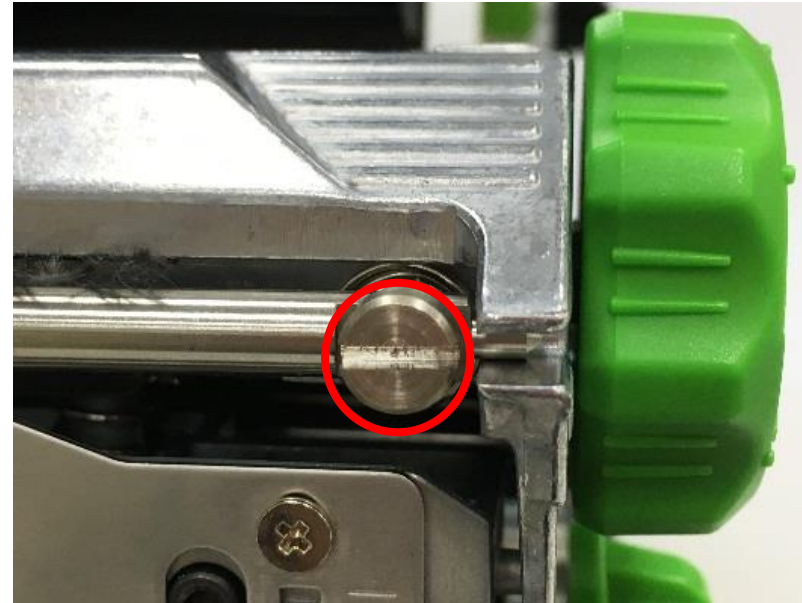

Wrinkle happens from label lower right to upper left direction



- Make sure the Print head Pressure Adjustment Knob is in correct position for the current media. Ex: 1~2", 3~4"
- Turn the screw clockwise per level and print to see if the wrinkle has g1.
- If the ribbon tension adjustment knob has positioned on the level of innermost side but doesn't improve the ribbon wrinkle, please switch the print head pressure at 1 level and print the label again to check if the wrinkle is g1.
- If the wrinkle can't be avoided, please contact the Customer Service Department of your purchased reseller or distributor for service.

Wrinkle happens from label lower left to upper right direction

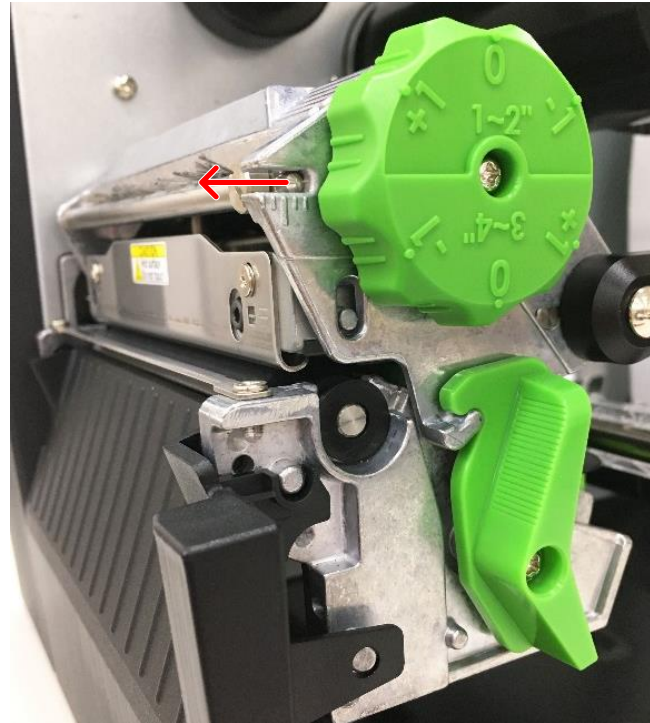
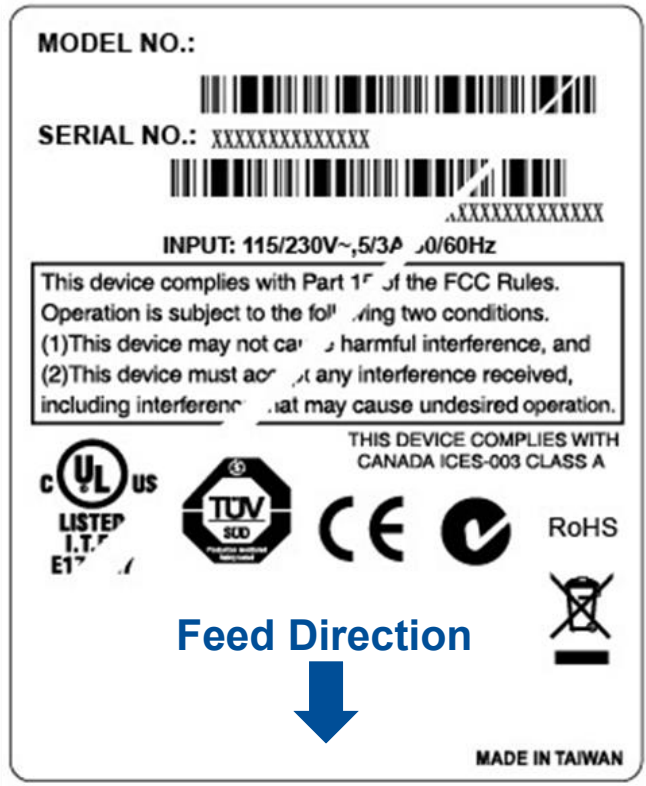

- Make sure the Print head Pressure Adjustment Knob is in correct position for the current media. Ex: 1~2", 3~4"
- Turn the screw counterclockwise per level and print to see if the wrinkle has g1.
- If the ribbon tension adjustment knob has positioned on the level of outermost side but doesn't improve the ribbon wrinkle, please switch the print head pressure at 1 level and print the label again to check if the wrinkle is g1.
- If the wrinkle can't be avoided, please contact the Customer Service Department of your purchased reseller or distributor for service.

5. Maintenance

This session presents the clean tools and methods to maintain the printer.

■ For Cleaning

Depending on the media used, the printer may accumulate residues (media dust, adhesives, etc.) as a by-product of normal printing. To maintain the best printing quality, you should remove these residues by cleaning the printer periodically. Regularly clean the print head and supply sensors once change a new media to keep the printer at the optimized performance and extend printer life.

■ For Disinfecting

Sanitize your printer to protect yourself and others and can help prevent the spread of viruses.

■ Important

- Set the printer power switch to O (Off) prior to performing any cleaning or disinfecting tasks. Leave the power cord connected to keep the printer grounded and to reduce the risk of electrostatic damage.
- Do not wear rings or other metallic objects while cleaning any interior area of the printer.
- Use only the cleaning agents recommended in this document. Use of other agents may damage the printer and void its warranty.
- Do not spray or drip liquid cleaning solutions directly into the printer. Apply the solution on a clean lint-free cloth and then apply the dampened cloth to the printer.
- Do not use canned air in the interior of the printer as it can blow dust and debris onto sensors and other critical components.
- Only use a vacuum cleaner with a nozzle and hose that are conductive and grounded to drain off static build up.
- All reference in these procedures for use of isopropyl alcohol requires that a 99% or greater isopropyl alcohol content be used to reduce the risk of moisture corrosion to the printhead.
- Do not touch printhead by hand. If you touch it carelessly, please use 99% Isopropyl alcohol to clean it.
- Always taking personal precaution when using any cleaning agent.

Cleaning Tools

- Cotton swab
- Lint-free cloth
- Brush with soft non-metallic bristles
- Vacuum cleaner
- 75% Ethanol (for disinfecting)
- 99% Isopropyl alcohol (for printhead and platen roller cleaning)
- Genuine printhead cleaning pen
- Mild detergent (without chlorine)

Cleaning Process:

Printer Part	Method	Interval
Print Head	<ol style="list-style-type: none"> I. Always turn off the printer before cleaning the printhead. II. Allow the printhead to cool for at least one minute. III. Use a cotton swab and 99% Isopropyl Alcohol or genuine print head cleaning pen to clean the print head surface. 	Clean the print head when changing a new label roll.
Platen Roller	<ol style="list-style-type: none"> I. Turn off the printer. II. Rotate the platen roller and wipe it thoroughly with the lint-free 99% Isopropyl Alcohol. 	Clean the platen roller when changing a new label roll
Peel Bar	Use the lint-free cloth with 99% Isopropyl Alcohol to wipe it.	As needed
Sensor	Use brush with soft non-metallic bristles or a vacuum cleaner, to remove paper dust. Clean upper and lower media sensors to ensure reliable Top of Form and Paper Out sensing.	Monthly
Exterior	Clean the exterior surfaces with a clean, lint-free cloth (water-dampened cloth). If necessary, use a mild detergent or desktop cleaning solution then use the 75% Ethanol to wipe it.	As needed
Interior	Clean the interior of the printer by removing any dirt and lint with a vacuum cleaner, as described above, or use a brush with soft non-metallic bristles then use the 75% Ethanol to wipe it.	As needed

Printer Part	Method	Interval
Linerless Printer	Please refer to Linerless Cleaning Kit User Manual for more information. 	<ul style="list-style-type: none">◆ Clean as needed or after printing every 1 km.◆ Please determine the maintenance intervals based on actual usage.

Revision History

Date	Content	Editor
2024/4/25	First release	Camille Pao



www.tscprinters.com